



Gross Weight Increase to 1370lb (621kg)

Classification:	Optional
Applicability:	All pre XS Europa aircraft
Compliance:	N/A

Introduction

The Europa aircraft was originally designed to operate at a maximum gross weight of 1300lb (590kg) and be equipped with the 80 hp Rotax 912 engine.

With the advent of more powerful but heavier engines being installed and the Tri-gear installation which adds about 35lb (16kg), the payload was diminished such that the XS version of the Europa had its new pre-moulded wing designed and tested to enable an increased weight of 1370lb (621kg) to be approved. Subsequently, the wet layup wings of the pre-XS Europas were tested to the higher specification and found to be acceptable for use with the aircraft at 1370lb. However, earlier tests had shown that reinforcement to the fuselage was also necessary, along with a re-designed socket for the wing's rear pin. Larger diameter spar pins, one which would prevent aft movement of the starboard wing's spar tip, were also deemed necessary.

It should be noted that the heavier maximum gross weight, take-off and climb performance will be reduced. If the Rotax 912 engine is fitted then a minimum static engine speed that should be achieved for take-off at weights above 1300lb is 5400 rpm. If a ground adjustable propeller is fitted, this setting will reduce cruise performance and an in-flight variable pitch propeller might be considered.

Full consideration of the effect that density altitude has on take-off and climb performance must be given when operating at maximum take-off weight. This modification will also allow the maximum airspeed (V_{ne}) to be increased from 150 kts to 165 kts.

The following text assumes that the structure of the aircraft to be modified has been completed and that the original builder or experienced person is to carry out the following work. If you are unfamiliar with the described techniques it would be wise to seek skilled help.

In summary, you will be replacing the 3/8" spar bushes with 1/2" bushes, replacing the wing rear pins and sockets, adding a tie-bar which runs between the rear sockets and laying up a strap on the port spar to hold the starboard spar.



Action

Prior to starting the modification work, with the wings rigged take measurements from some convenient point at each wing tip to a point on the fuselage, the rear of the tailplane fairing for example, to enable accurate checking that you don't introduce wing sweep when replacing the wing rear sockets. Keep a note of these measurements and of the points they were taken from.

Spar bush replacement

The 3/8" diameter bushes in both wing spars and the seat back need to be replaced with 1/2" diameter bushes. To exchange the bushes you will be cutting the old ones out with a hole saw and bonding the new ones in. It is vital that the centre distances in both wings and the cockpit module are identical; each will be used a jig for the other.

To remove the bushes from the port wing nearest the root rib, it's best to remove the rigging socket first. Careful use of heat to soften the Redux will be necessary and a broad tool such as a wallpaper scraper to lever from underneath. Don't use anything which will be levered into the spar. Leave a few bits of the original fillet intact to aid repositioning later.

Insert the drill guide S10, which is for a 1/4" pilot drill, into the 3/8" bush. Using a 3/4" hole saw drill through the bush flange and half way through the spar or all the way through the seat back. Drill from the other side of the spar to completely remove the bush. Allow swarf build up to clear by withdrawing the hole saw regularly, also don't cut too fast to avoid an excessive build up of heat. Go from bush to bush to allow things to cool down. Use a chisel or similar to remove the old bush flange which may remain stuck to the spar.

You may need to open the holes slightly with a round file to enable the bush to fit; don't overdo it or file in one direction only. You'll need to open up the hole diameter in the rigging cups from 3/8" to at least 1/2". Do this by drilling or filing before you install the new bushes.

With the bushes installed dry (no epoxy) at this stage, carry out a trial assembly of the wings only to ensure that the spar pins will go through. Make adjustments as required.

If you find difficulty inserting the pin, one of the half bushes may be out of line. To assess which bush is out of line, remove one at a time and re assemble the wings.

Install the new bushes with wettish flox applied to the knurled shank, ensuring that no flox gets in the rigging box. Finally, bolt the spars together using 1/2" bolts and nuts, taking care that the spars are parallel and that the bolts are perpendicular to the spars.

Ensure that the whole assembly will not stick together by using a release agent of one form or another on mating parts. Grease on the bolts, plastic sheeting or polythene packing tape between the spars are some suggestions.

Leave undisturbed until the epoxy has cured, then separate the spars.

Finally, after checking the positions of the bushes in the seat back using the port wing spar as a jig, bond these in. Use the bolts to maintain alignment between the port spar and the seat back bushes and leave to fully cure.

Spar rigging socket

Clean off any old adhesive from the rigging sockets and scuff sand their bonding faces. Scuff sand also the spar and cockpit module where the rigging sockets will fit.

It's most practical to fit one rigging socket at a time. Fit the port spar's socket to the cockpit module and rig the port wing, securing the spar end with the ½" nut and bolt. When fitting the starboard wing's rigging socket to the port spar, you can rig both wings together away from the fuselage.

Spar pins

There are two different spar pins; one being a pip-pin the other a plain steel pin. The pip-pin is to be used on the port side of the aircraft to retain the tip end of the starboard wing spar in the event of an overload. The rigging socket is not regarded as a structural component. The tip end of the port spar is restrained by the starboard spar behind it.

Pip-pin

The pip-pin supplied is slightly too long which enables fine adjustment of its fit in each individual aircraft. To be effective, the pip-pin balls should be no further than 0.020" (0.5 mm) from the rear of the rigging socket.

To strengthen the rigging socket hole against which the pip-pin will react, a hardened steel washer is to be bonded in place. A sectional view through the spar at the pip-pin location is shown in figure 1.

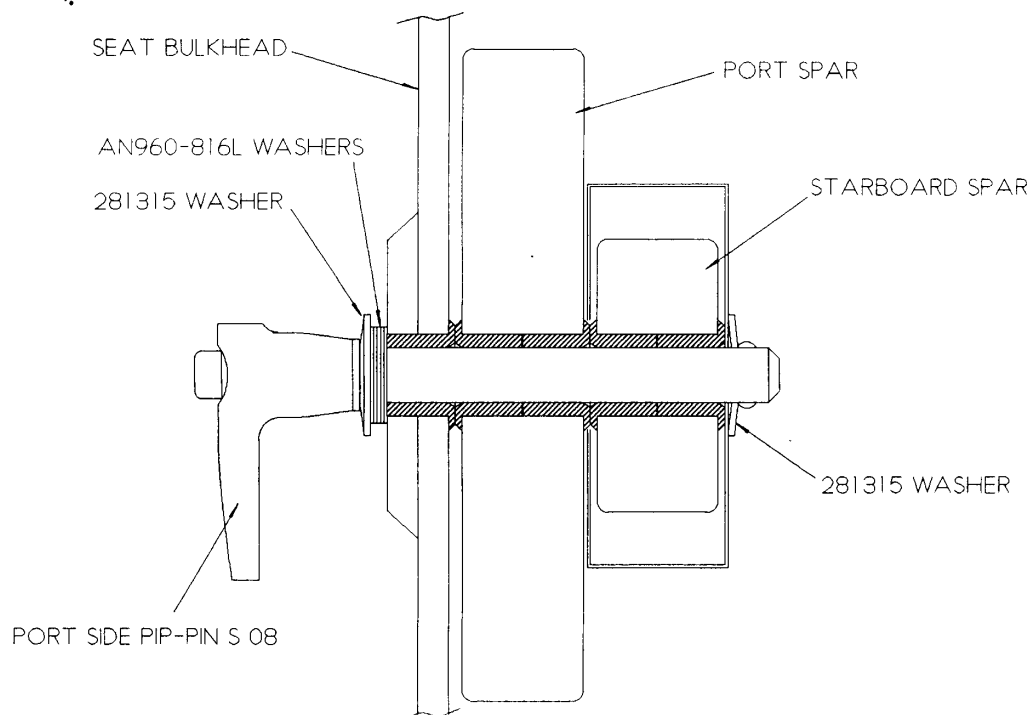

Fig 1. Section through port side spar pin bush area.



Set the port wing on supports with the trailing edge uppermost. Scuff sand the rear face of the rigging socket, which is bonded to the port wing spar, in preparation for bonding. Scuff sand also the hardened washer both sides. You will bond the washer to the rigging socket then retain it with a ply of 'bid'.

Prepare a piece of 'bid' about 50 mm x 50 mm (2" x 2") and mix up a small quantity of epoxy (approx 50 g). Keeping enough epoxy to wet out the 'bid', mix a small quantity of floc into the rest to make a wettish consistency. Apply the floc to the concave side of the slightly conical washer and then position it over the hole of the rigging socket. Use one of the 1/2" bolts to centre the washer then, with floc added around the outer edge of the washer to make a fillet, apply the single ply of 'bid' which will retain it. Although the 'bid' covers the hole, it is best to leave it now and clear it out after cure to avoid disturbing it. It would be a good precaution to apply a thin layer of grease to the bore of the bush to avoid any epoxy drips sticking.

After cure, cut open the hole through the 'bid' and sand away the glass fibre within 2 - 3 mm (1/8") of the hole to ensure that the pip-pin balls contact the washer when installed rather than the glass fibre.

Pip-pin length adjustment

Rig the wings into the fuselage and install the pip-pin in the port side seat back bush. The pip-pin's button needs to be depressed until the pin is fully in. Check that the button springs out after insertion. If it doesn't, there is something preventing the balls from emerging.

Without pressing the button in, pull on the pin until the balls contact the hardened washer. Measure the gap between the underside of the pin's head and the seat back. This gap should be taken up with a spacer which is between 0.1 and 0.5 mm (0.004" and 0.020") less than that measured.

To make up the spacer, select a number of the AN960-816L washers, which are approximately 0.8 mm (0.032") thick each and include one slightly conical hard steel washer over them which adds another 2 mm (0.080"). Refer to figure 1. Slide the calculated combination onto the pip-pin and assemble the wings. Check that the pin's button pops out, so engaging the balls and that the free play is less than 0.5 mm (0.020").

Position the washer assembly in place with a greased 1/2" bolt and pot around them with a mix of rapid epoxy with floc to make a fairly stiff mix. The idea is only to retain the washers when the aircraft is derigged. To make the washer assembly more secure add a couple of plies of 'bid', lapping 10 - 20 mm (3/8" - 3/4") onto the seat back. Do this after removal of the bolt and ensure that no glass fibre is left between the washer and the pin head, otherwise the pin length adjustment will be affected.

Starboard spar pin

The starboard spar pin SO7 will require the threaded end cutting off so that it measures 85mm (3-3/8") from under the head. Round off the end to enable easy location. A sectional view through the spar at the starboard pin location is shown in figure 2.

Fig 2. Section through starboard side spar pin area.

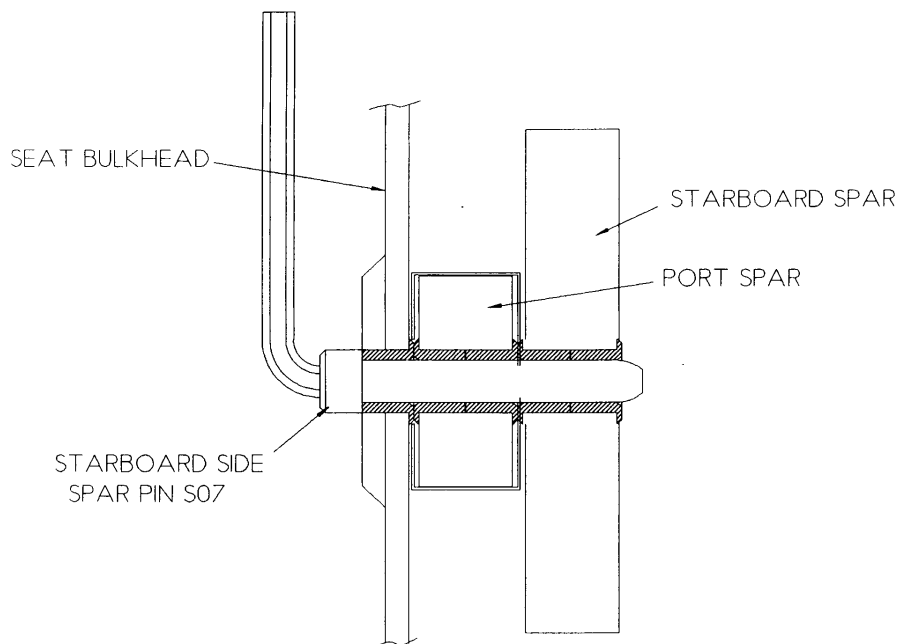

Spar pin safety latch

The receptacle of the starboard spar pin safety latch will require its slot being made slightly bigger to accommodate the spar pin's handle. Check that the latch still closes over the handle to lock it in place. See figure 3.

Fig 3. Starboard spar pin safety latch.

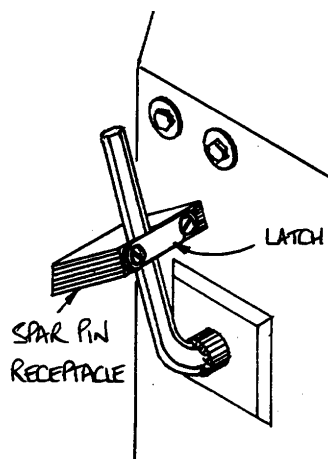

The safety latch on the port side where the pip-pin is used can be removed altogether.

Pin identification



Although the safety latch should act as a reminder, it is possible to rig the aircraft and put the spar pins in the incorrect locations so it is important to identify the pins and the holes in the seat back in some manner. For example, paint the handle end of the port side pip-pin red, the starboard pin green and paint a matching colour around the holes. Alternatively, attach the pip-pin to a strap which is secured to the fuselage, via the seat belt attachment bolt for example, to avoid it being used on the starboard side.

Aileron quick connect bellcrank

At full aileron deflection (roll to starboard) there is the possibility that a corner of the aileron quick connect bellcrank CS15P, which is mounted in the fuselage, may contact the 1/2" pip-pin. With the aircraft rigged and the aileron controls correctly adjusted, the W16P bellcrank will not contact the pin. See figure 4 and confirm this on the aircraft.

Fig 4. Detail of port side aileron quick connect bellcrank.

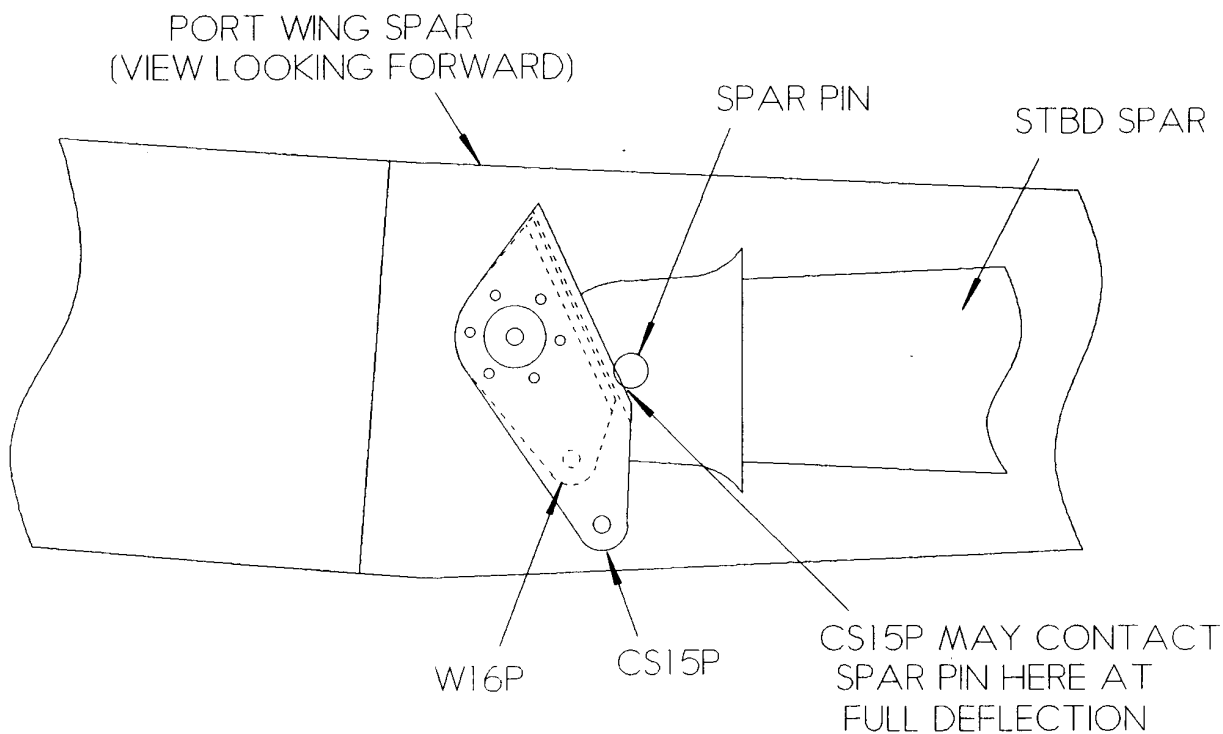

To avoid contact with the pin, the corner of CS15P should be removed as shown in figure 5. Ensure that the inner corner is radiused as shown.

On installation, check that there is clearance between the spar pin and CS15P, making any small adjustment as necessary.

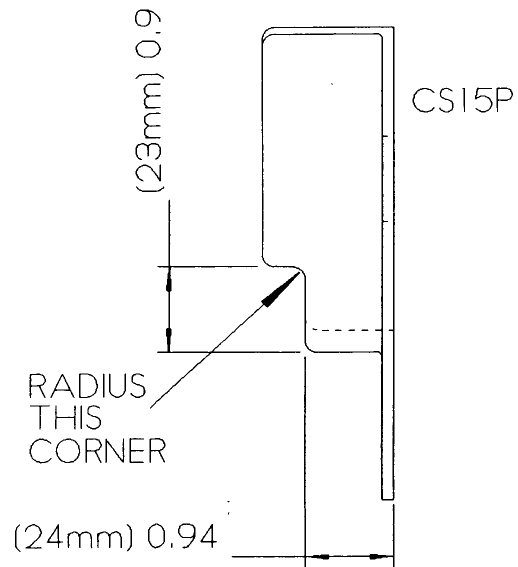

Fig 5. Cut-out

as required in CS15P.

Wing rear pin sockets and tie-bar

The original socket (W26) for the wing rear pin is a single piece machined fitting which is bolted to the fuselage side. This will need removal and replacement with a socket assembly which articulates a few degrees to allow for wing bending.

Supporting the fuselage sides where the rear sockets are attached will be a tie-bar assembly, incorporating the fittings W34 and a steel tube W36.

The wing rear pin will also need replacement as the pip-pin hole in it is in a different position to the original.

In preparation for later assembly, hold the W26A and W34 fitting together so that their flat circular faces match each other. Drill one of the 1/4" holes into the W34 using W26A as a guide. The other two holes will be drilled on assembly in the fuselage. The holes are not pre drilled in W34 as each assembly may be slightly different.

Rear sockets assembly

Each rear socket is an assembly of a W26A, W26B and W26C. The W26A is the main body and is oriented with the smaller hole between the lugs at the bottom. W26B is the socket housing which slots between the two lugs of the body with the double chamfered face innermost. These chamfers allow the housing to rock a limited amount. Holding W26A and W26B together is W26C, the barrel. See figure 6.

Fig 6. Exploded view of W26 wing rear pin socket assembly

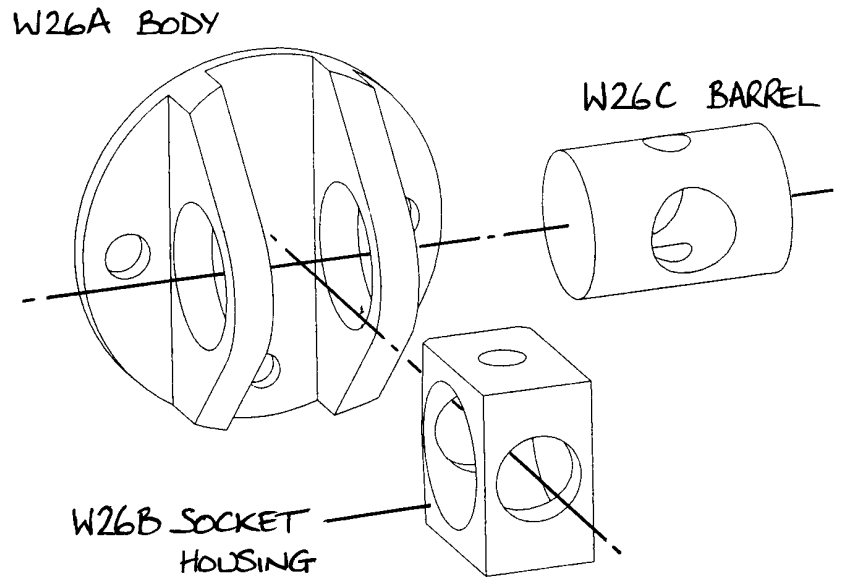

Slide the barrel in to the assembly from one side and rotate it so that the large and small holes align with the holes in the housing. Check that your 1/4" diameter BLS4R11N pip-pin will pass through the small hole without hindrance. A check with the pip-pin including the new W24/5 wing pin would also be sensible at this stage.

The socket assembly should be finally assembled using Loctite 638 to lock the barrel and housing together, but allow the barrel to rotate within the lugs of the housing. Make sure that the parts are clean and free from grease before this final assembly. If the barrel does become stiff in the housing, the use of a bar in the socket will enable it to be moved. It does not matter if the assembly remains stiff.

Wing rear pin replacement

Due to the repositioning of the pip-pin hole in the wing rear pin (W24) the original one must be removed and discarded.

To remove the existing W24 pin, which you will have bonded in, first try removing it using a stud extractor or other device such as a pipe wrench. If it doesn't move, heat will be required to soften the adhesive.

Insulate the glass fibre of the wing root surrounding the pin and then use foil or thin metal sheet to reflect the heat.

Carefully and gently heat the end of the pin using a heat source, such as a small blow torch on a low setting, which can be precisely directed. You should be aiming to heat the pin only to a temperature that is just too hot to touch, nothing more. The heat should travel down the pin and soften the adhesive and allow its removal. Don't try to hurry this but allow time for the heat to travel to the thread of the pin. After removal of the pin, allow the wing root to cool and install the new W24 pin provided using Redux 420 adhesive or Loctite 243 to secure it.

When installing the pin it must be installed in the W26 socket assembly with the pip-pin to ensure it is not screwed in too far. Screw the pin in to the wing until it is prevented from turning further by the contact of the socket assembly with the wing root. Unscrew the pin just enough to ensure that the pip-pin hole is oriented vertically.

Socket assembly installation

Firstly, remove the existing W26 sockets. Cut away completely the GRP top-hat stiffener inside the fuselage first then remove the bolts securing the W26 sockets to the fuselage. Crack off the sockets with a sharp tap vertically up or down. Gentle heating may be used to soften the adhesive if required.

In Tri-gear aircraft, the forward, upper part of the front, outboard main gear support ribs will need to be cut away to give access to the wing rear socket retaining bolts. These ribs and the front, inboard ribs will also need to be cut away to allow the tie-bar through, but this could be done later.

The new W26 socket assembly is 2.5 mm (0.1") deeper than the original socket so this amount will be required to be removed from the existing mounting pad. Due to the revised shape of the socket's mounting face it may be prudent to remove the existing mounting pad entirely and make a new one in a conical shape as shown in figure 7.

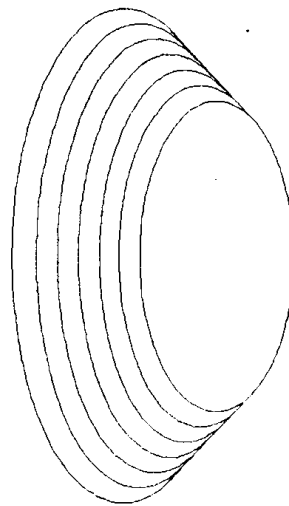

Fig 7. Plywood mounting pad.



Assuming a new mounting pad is to be made, assess its thickness in the following manner:

Rig the wings to the fuselage with the W26 socket assembly attached to the wing rear pins with the pip-pins. Ensure that the socket housing is midway between its extremes of angular movement. Place temporary wedges between the back of the housing and the body if necessary to hold it in this position.

The wing incidence will be set by the wing forward pin however, to check that there is no wing sweep, take measurements from the same points on the wings and fuselage on port and starboard sides that you used at the beginning and make adjustments as required.

Measure the gap between the rear of the W26 socket assembly and the fuselage side. If it is less than 5 mm (3/16"), make a layup on the fuselage side, from 'bid' pieces approximately 1 cm larger than the socket's rear face, to reduce the gap to a maximum of 1 mm. Each ply of 'bid' will be approximately 0.25 mm (0.01") thick. Make this pad on a plastic sheet and apply it in one piece.

If the gap is greater than 5 mm (3/16") up to a maximum of 13 mm (1/2"), make a mounting pad from good quality plywood to reduce the gap to approximately 2 mm (3/32"). The outer face of the mounting pad should be at least the same size as the socket and have chamfered edges of 45° to 60° see figure 7.

Separate the wings sufficiently far to gain access to the socket pads. Using Redux 420, or standard epoxy, mixed with flox bond the mounting pads onto the fuselage sides in the relevant places ensuring that the gap of approximately 2 mm (3/32") between the socket and pad remains. Either immediately or after the adhesive has cured, layup 4 plies of 'bid' at ± 45° over the mounting pads lapping onto the fuselage at least 25 mm (1") all around. Cover the entire layups with peel ply and allow to cure.

Attaching the sockets

Scuff sand the rear face of the W26A socket body and remove the peel ply from the fuselage mounting pads. Mix a quantity of Redux 420 adding flox to stiffen it and apply it to the rear faces of the W26A ensuring none gets onto the lift pins.

Reposition the wings with the spar bolts in place checking finally that the wings are not swept forwards or rearwards.

Now walk away and don't allow anything to be disturbed until the adhesive has cured properly.

After full cure, check again that nothing has moved. Carefully remove the spar pins and pip-pins and slide the wings out of the fuselage, starboard wing first.

Tie-bar

As the trailing edge lift pin also acts to contain drag loads and the forward component of lift which is produced at high angles of attack, a tie-bar will be fitted across the fuselage to react these loads. A general arrangement of the tie-bar assembly and associated parts is shown in figure 8.

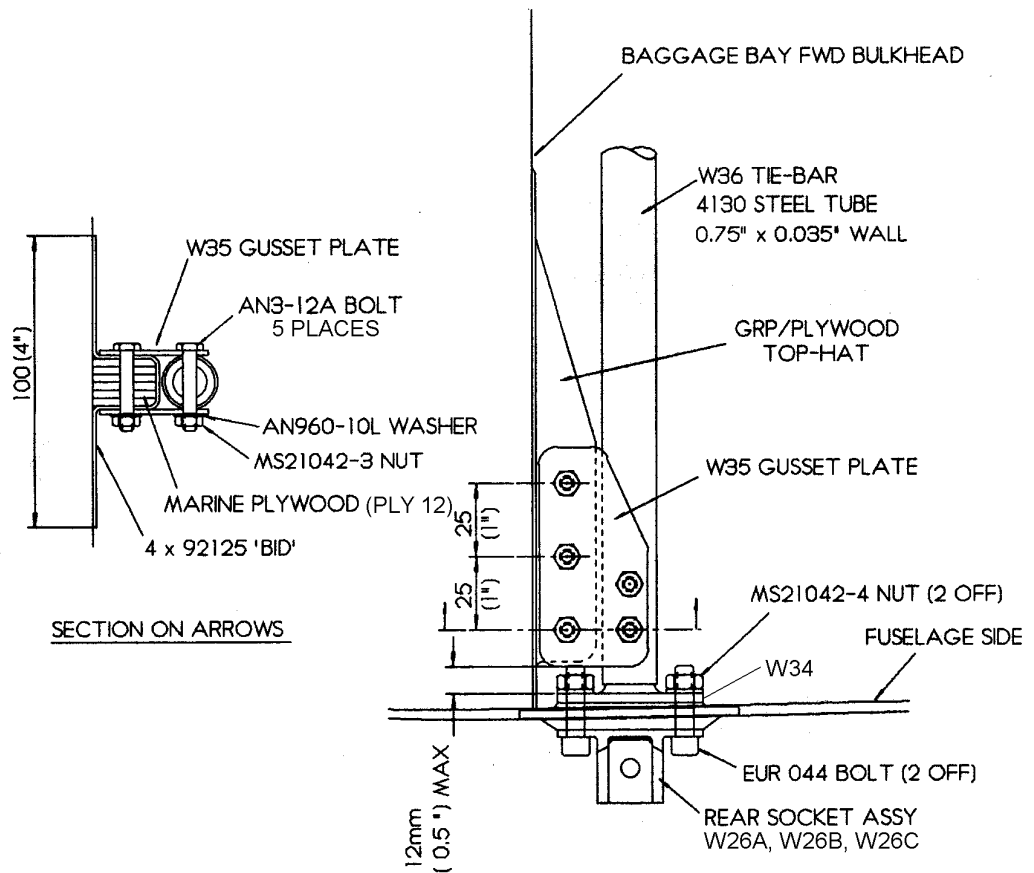

Fig 8. Top and sectional view of tie-bar and socket (port side).



Using the W26A body as a guide, drill the two 1/4" and one 3/16" holes right through the fuselage. Take care to drill straight so that the holes don't diverge, otherwise the bolts may end up close to the edge of the W34 fitting. The two 1/4" holes should line up with the previously drilled holes from the original socket. Temporarily locate the W34 fitting inside the fuselage using the EUR044 bolts and EUR046 plain nuts for now.

As the fuselage side is at a slight angle to the aircraft centre line where W34 sits, a shim of epoxy and floc will be required on assembly. Take this into account when positioning W34 at this stage. Mark a line across the top of the centre tunnel (and the ribs in Tri-gear aircraft) in the baggage bay to represent the 3/4" diameter steel tube tie-bar which will be fitted between the W34 fittings.

It will be seen that it is necessary to cut a slot in the centre tunnel. Cut this slot and adjust its size to leave a clearance around the tube of approximately 3mm (1/8").

In Tri-gear aircraft, cut slots in the main gear ribs as required, but rather than a narrow slot as in the central tunnel, chamfer the slot sides at a 45° angle where possible. This affords better access for the tie-bar and will make installation of new plywood to reform the ribs easier.

Again, temporarily install the W34 fittings, with the tie-bar, and insert the EUR044 bolts in each side. The thread on the EUR044 bolts should be cut off, but ensure that at least two threads protrude through the nut.

Gusset Plates

In addition to reacting the tensile/compressive loads it is necessary to provide sideways stiffness for asymmetric loads. This is done via two plywood blocks laminated onto the baggage bay front bulkhead, which are connected to the tie-bar by means of gusset plates. Refer to figure 8.

Make up the two plywood blocks according to figure 9. As each aircraft is bound to be slightly different, the width of the blocks must be determined by measurement.

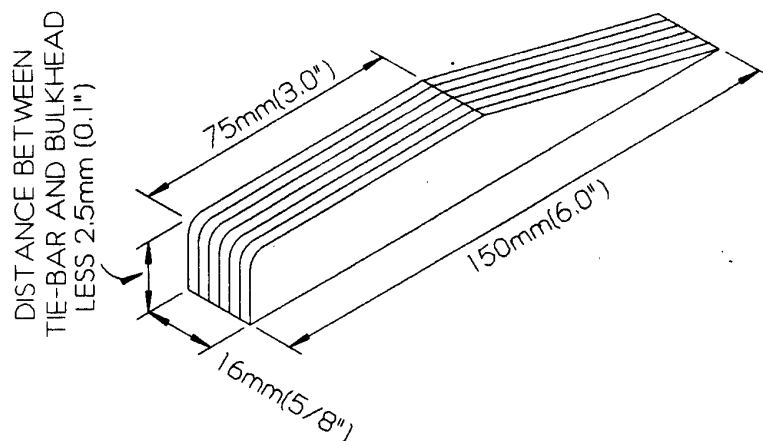

Fig 9. Plywood block for gusset plates.

Scuff sand the bulkhead where the plywood blocks fit and the surrounding 5 cm (2"). Using rapid epoxy spread over the entire bonding face, bond the plywood block on to the bulkhead, as far outboard as possible, but allowing space for the shortened EUR044 bolt and aligning it with the tie-bar. Remember to allow 2.5 mm (0.1") between the block and the tie-bar for the thickness of glass fibre which will go over the block.

Once secure, remove the tie-bar and W34 fittings and layup four plies of 'bid' at $\pm 45^\circ$ over the plywood block, lapping onto the bulkhead all around as shown in figure 8. Make fillets with floc in the corners first to prevent the formation of air bubbles. Cover with peel ply and allow to cure.

After cure, remove the peel ply and reposition the tie-bar assembly. Position a gusset plate on top of the plywood block and tie-bar such that its outboard edge is no further than 12mm (0.5") from the flange of W34 and, using the two holes as a guide, drill right through the tie-bar centre-line with a 4.8 mm drill. Install an AN3-12A bolt in each hole after drilling to ensure alignment for the next hole.

Now mark a line on the upper gusset plates which is central to the plywood block, then mark the centres for three holes, each 25 mm (1") apart and 13 mm ($\frac{1}{2}$ ") from the edge of the plate. Drill right through with a 4.8 mm drill.

Next, install two W35 gusset plates to each end of the tie-bar, one above and one below, bolting them to the tie-bar with AN3-12A bolts and MS21042-3 nuts with an AN960-10 washer under it. Drill through the lower gusset plate with the last 3 holes and install AN3-12A bolts in these also. Don't add the nuts to these bolts yet as you're just about to remove the assembly again.

Final assembly of tie-bar

Initially remove all components identifying where they were fitted for re-assembly. Clean away any burrs and swarf caused by drilling. At this stage it would be a good idea to paint the tie-bar to protect it against corrosion so that it's dry ready for final assembly.

Prepare each side of the slot in the central tunnel of the cockpit module for a glass fibre layup by removing the upper skin and foam to expose about 10 mm ($\frac{3}{8}$ ") of the lower skin. See sectional diagram in figure 10.

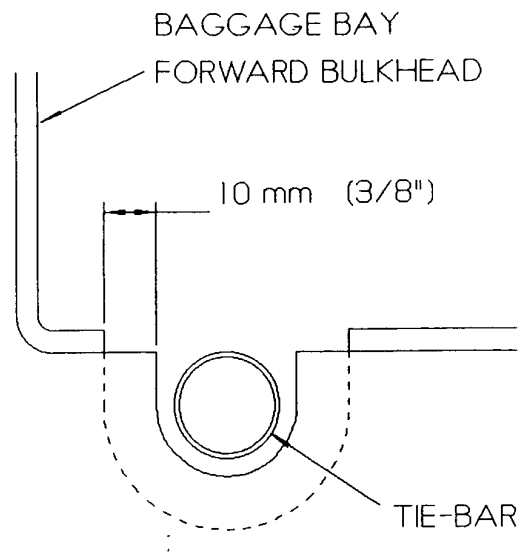

Fig 10. Section through baggage bay centre tunnel.



The tie-bar can now be installed for the last time. For the final installation of the tie-bar assembly make a stiff mix of floc and spread this on the flat face of the W34 fittings to form a shim to take up the uneven gap between them and the fuselage sides. With the tie-bar in place, fit the assembly into the fuselage and install the EUR044 bolts and MS21042-4 nuts and the EUR045 bolts (suitably shortened similar to the EUR044 bolts) and MS21042-3 nuts.

Do not fully tighten the bolts at this point just tighten them enough to prevent movement of the W34 fittings. Scrape away any excess floc from around the W34s.

Install the gusset plates with the AN3-12A bolts and MS21042-3 nuts and AN960-10 washers.

Central tunnel slot closure

The final task to be done is to close the slot in the tunnel, tying the tie-bar into it in the process. Cut pieces of 3 mm foam to fit into the slot across the top and down the angled sides. The side pieces may be in two pieces each to take it around the tie-bar. Scuff sand the bonding areas each side of the slot.

Layup

Layup 2 plies of 'bid' at $\pm 45^\circ$ on plastic sheeting at least 30 cm x 20 cm (12" x 8"). Cut a strip to fit into the slot and lay it to join the inner skins together. Drape it over the tie-bar, cutting it to allow it to go around the tie-bar at the sides. See figure 11.

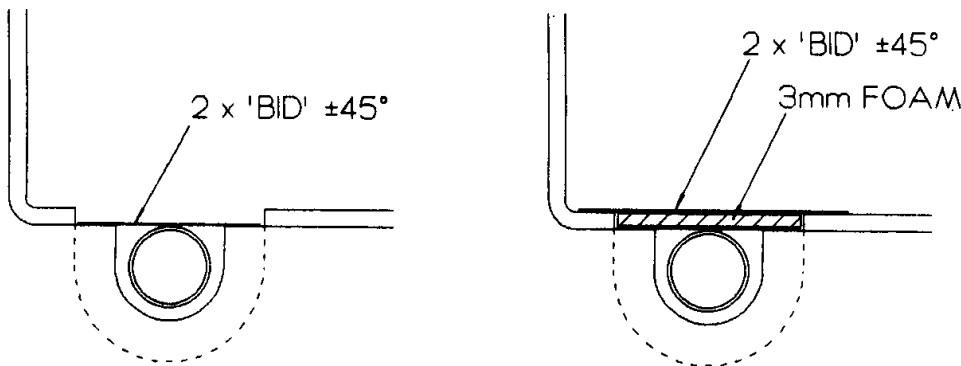

Fig 11. Section through tunnel detailing layup sequence.

Apply a layer of floc to the underside of the 3 mm foam pieces and lay them in place over the first layup.

Next, coat the upper portion of foam with floc and finally layup 2 plies of 'bid' at $\pm 45^\circ$ over the foam lapping onto the surrounding glass fibre and the tie-bar by about 20 mm (3/4").

Cover with peel ply and allow to cure.



Tri-gear main gear ribs

Using 3/4" plywood, make pieces to fit into the ribs where they have been cut away to accommodate the tie-bar.

Bond these pieces in place using flox then layup over them with 3 plies of 'bid' at $\pm 45^\circ$ lapping the first ply on to the existing ribs by at least 5 cm (2"), the subsequent plies being 12 mm (1/2") shorter each time. Immediately layup 3 plies of 'uni' along the top of the ribs and down each side 25 mm (1") with the fibres oriented along the ribs. Overlap the existing 'uni' plies by at least 5 cm (2").

Spar strap

When the wings become loaded in flight, the spars within the fuselage bend, as well as the wings themselves. Due to the spar pins being supported by the seat back bulkhead only, the spars try to twist as well as bend.

To limit the twisting effect, a 75 mm (3") wide glass fibre strap is to be attached to the port wing spar at the aircraft centre-line. The strap is to be laid up directly around the starboard spar, which will be suitably treated with release tape, to ensure a perfect fit.

Preparation

Starboard spar

To accommodate spar bending, the strap needs to be made with some clearance at each end over the spar's upper edge. Without this, the starboard spar would tend to shear the strap from the port spar as it bends. To form this clearance, cut a piece of thin card to the width of the spar and at least 90 mm (3 1/2") long and cover it with release tape.

Using two 3 mm thick spacers placed on the spar as shown in figure 12, position the card former between them so that it curves and, using the release tape, attach it to the spar. Wrap the release tape, all around the spar trying not to distort the curved shape of the card. It might be wise to support the card in various places underneath so you don't lose the curve.

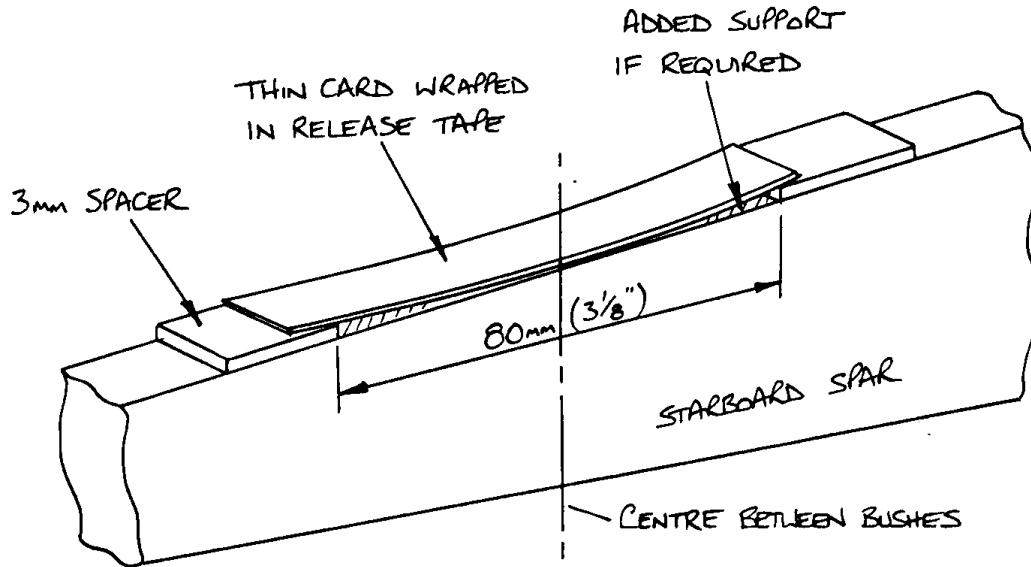

Fig 12. Former position on spar.

Port spar

Scuff sand the central 15 cm (6") all around the port wing spar in readiness for bonding the strap to it. Support the port wing, leading edge down and arrange it such that the starboard wing can be rigging in position with it, but don't put them together at this stage.

Layup

Cover an area of your work bench with plastic sheeting, then directly onto it make two different layups. One will be the strap, the other will form two brackets.

- Brackets - Layup 2 plies of 'bid' at $\pm 45^\circ$ large enough to cut two 90 mm x 90 mm (3" x 3") squares.
- Strap - Layup a strip large enough to cut a piece 350 mm x 90 mm (14" x 3") to the following schedule.

2 x 'bid' at $\pm 45^\circ$.
 2 x 'uni' (fibres running lengthwise).
 2 x 'bid' at $\pm 45^\circ$.

Position the bracket layups onto the centre of the port spar, lapping just 25 mm (1") onto the spars rear face, one at the upper edge, the other at the lower edge. See figure 13. For now, leave the bracket's pieces hanging down.

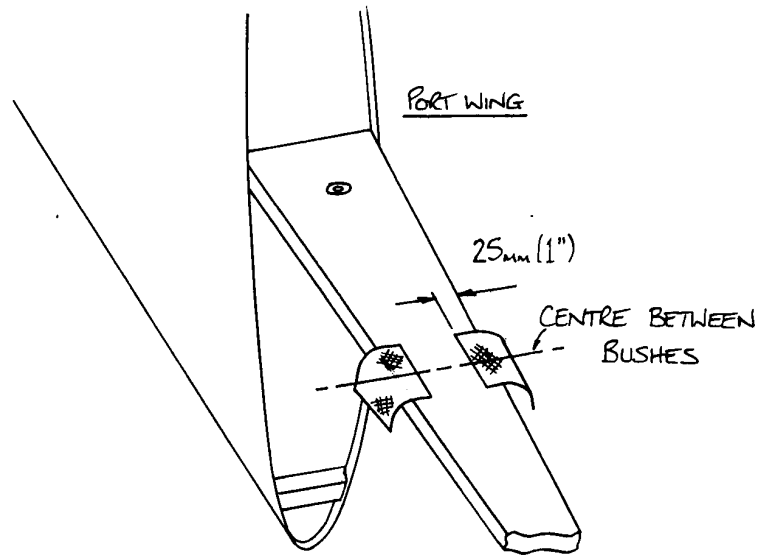

Fig 13. Bracket plies in position on port spar.

Now position the starboard spar onto the port spar and insert the spar pins or two ½” bolts through the spar bushings. Ensure that the spars are properly together, use clamps if necessary but don't squeeze the centres of the spars together.

With the spars together, wrap the bracket layups around the starboard spar. See figure 14.

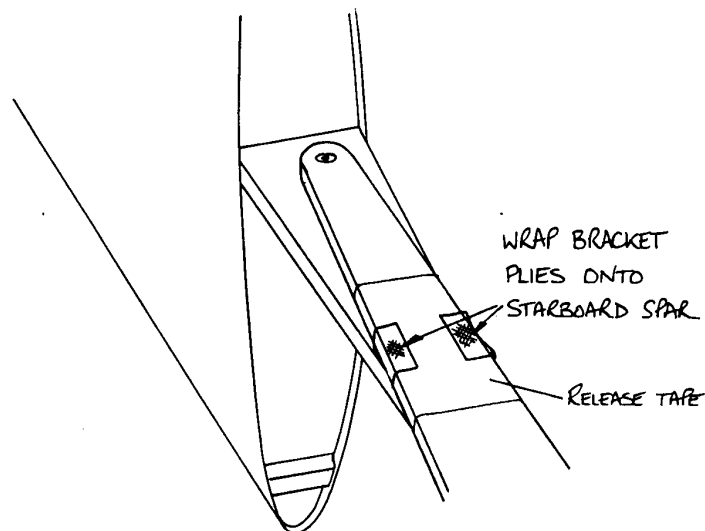

Fig 14. Brackets wrapped around starboard spar.



Apply floc to make a fillet between the bracket layups and the port spar then lay on the strap layup, over the brackets wrapping around onto the forward face of the port spar. The strap is not meant to overlap here, so trim the ends if necessary.

Having made sure that the layups are properly in place, leave to cure.

After cure, remove the spar pins and separate the spars. Trim the edges of the strap to remove sharp edges, adjusting the strap's width to no less than 75 mm (3"). See figure 15.

Note: *It may be necessary to separate the spars with a scissor jack, but be careful not to apply any impact load.*

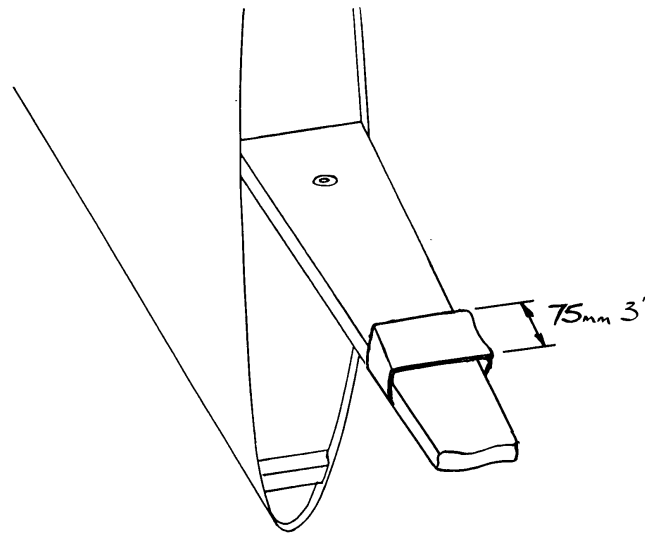

Fig 15. Spar strap trimmed to size

Finally remove the release tape and card former from the starboard spar.

Placarding

The placard stating maximum gross weight should be amended to reflect the increase to 1370lb. Also, whether placarded or marked on the airspeed indicator, V_{ne} should be altered to be 165 kts.

Note to operators of aircraft on a UK Permit to Fly

After completion of the modification, a worksheet detailing the work carried out, signed by your inspector, should be sent to the LAA with a request for permission to conduct the necessary flight test. The test flight will be carried out at a gross weight of 1370lb and will reach a V_{ne} of 165 kts. You will need clearance to do this from LAA Engineering in the form of a Permit Flight Release Certificate (PFRC).

After the test has been carried out, the flight results and the 'Operating Limitations' card should be sent to the LAA prior to the aircraft being given a full permit to fly.

Other Countries

Before the aircraft is returned to service, check with your Aviation Authority what testing is required.

