Speed Kit (Tri-Gear aircraft)

Classification: Optional

Applicability: Tri-gear Aircraft

Compliance: N/A

Introduction

The addition of fairings to the flap hinges, landing gear legs and wheels are found to reduce drag sufficient for an extra 10 kts to be achieved in cruising flight.

Also, the fairings provide a certain amount of protection to the components around which they are fitted and enhance the appearance of the aircraft. All fairings are made with a white gel coat but for a perfect colour match with the rest of your aircraft you may need to paint them.

A general arrangement drawing shows the fairings associated with the flap hinges and main gear is shown in figure 1.

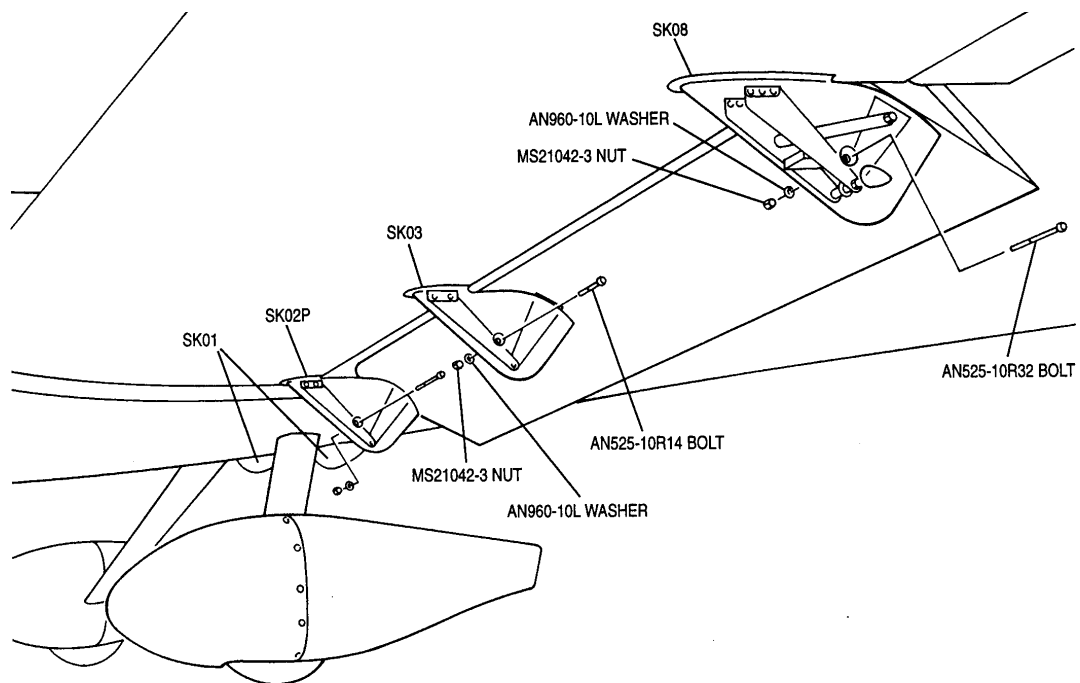

Fig 1. General arrangement of flap hinge and main gear fairings.



Installation

Fuselage flap hinges

To ensure that water doesn't collect in any of the fairings, drill a hole of at least 3 mm (1/8") at their lowest points.

The simplest fairings to fit are the blister fairings which cover the hinges for the flap operating cross-tube which protrude through the fuselage underside. These, and the other fairings, may require some of the flanges trimming a little.

Ensure that the fuselage skin around the hinges is clean. Apply a thin bead of white silicone (rubberised bath sealer) to the flange of the fairing and then position the fairing in place. Wipe the excess silicone off before it has solidified. The fairing may stay in place on it's own whilst the silicone sets but it is advisable to tape it to prevent it moving. Don't be too generous with the silicone as, once set, it will stick quite firmly and make removal for maintenance difficult.

Inboard and mid flap hinge fairings

To fit the flap hinge fairings to the wings, it is probably most convenient to de-rig the aircraft and support the wings upside down. Being able to operate the flaps is also necessary to ensure that there is clearance between them and the fairings.

The inboard flap hinges are handed port and starboard due to the flange being on one side only. The flange is to be on the outboard side of the fairing to clear the root fairing. The two mid flap hinge fairings are identical.

The wing mounted fairings are secured by means of a single bolt, which goes through the angled hinge arms W19 and W20, along with silicone sealant which seals the flanges.

First, drill through the centre of the dimples in the fairings with a 4.8 mm drill then, holding the fairing in position on the wing (with flaps down) mark the hinge arm through the hole. Remove the fairing and drill through the flap hinge arm where marked with a 4.8 mm drill.

Install the fairing using silicone sealant on the flanges and secure it with an AN525-10R14 bolt, MS21042-3 nut and AN960-10L washer.

Outboard flap hinge

The outboard flap hinge fairing is installed in a similar manner to that of the other flap hinge fairings except, due to the width, a longer bolt is required.

When you have the fairing in the best fit position mark both TGW21 plates through the 4.8 mm holes in the dimples. Remove the fairing and drill both TGW21 plates separately.

Install the fairing using an AN525-10R32 bolt, MS21042-3 nut and AN960-10L washer and silicone to seal the flanges to the wing underside.

Nose gear fairings

Five separate mouldings make up the nose-gear fairings; two for the wheel and fork, three for the leg and pivot housing. See figure 2. The wheel fairing is attached to brackets whereas the leg fairing is secured with silicone adhesive. The front piece of the leg fairing assembly is attached to the leg fairing halves using bolts to enable access to the wheel fork pivot nut so that adjustments to the shimmy damper may be made without removing the fairings completely.

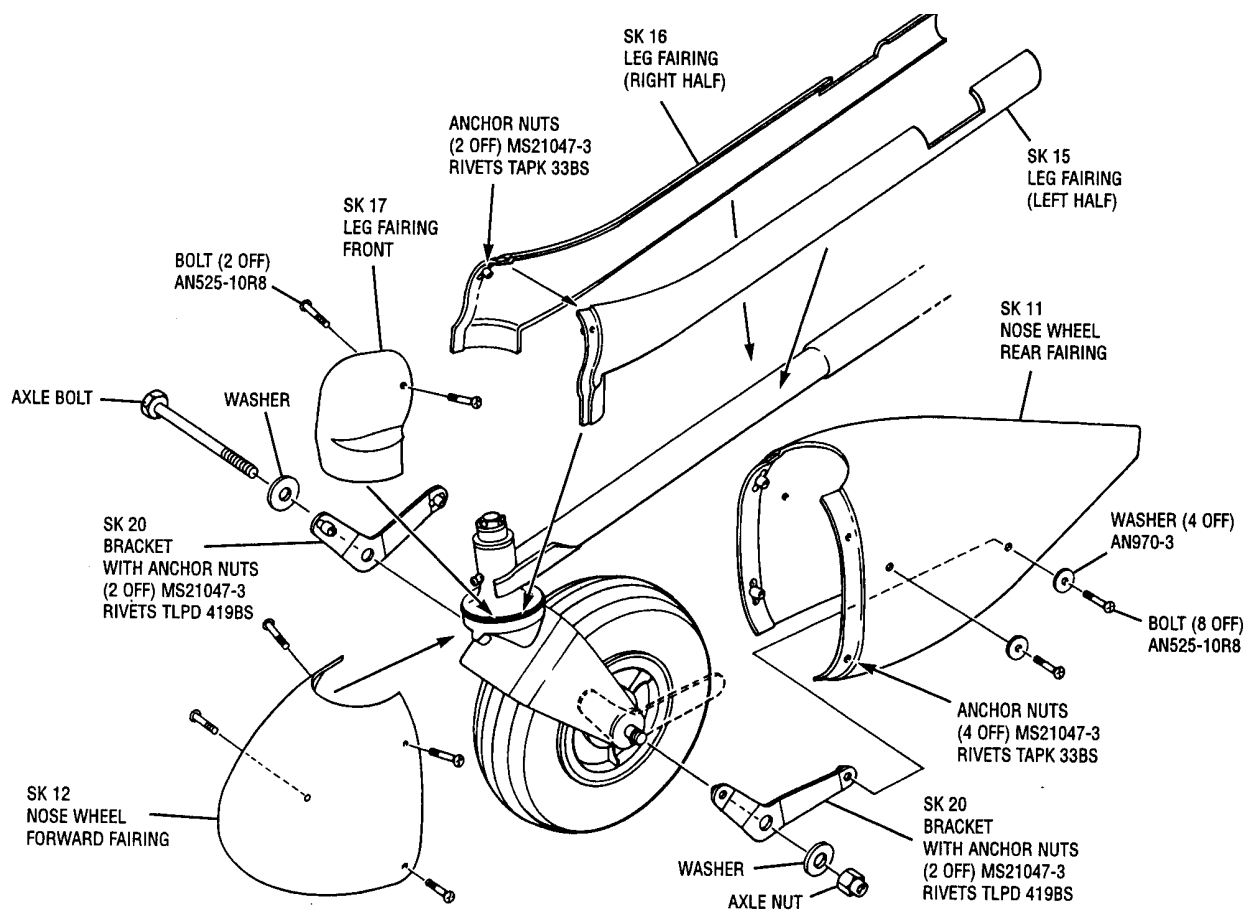

Fig 2. Nose Gear Fairings



Preparation

Nose Leg fairing

The leg fairing assembly is to be positioned such that the front part is centred around the pivot housing. The two half fairings are to be attached to the leg using silicone as an adhesive and the front section is attached to these fairings using AN525-10R8 bolts.

Initially, assemble all three parts together on the leg, using adhesive tape to hold them in place and make any adjustments that may be required to enable a good fit.

With only the leg fairing halves in place on the gear leg, note the clearance there is between the pivot housing and the flange onto which the front part locates. Choose a suitable place for MS21047-3 anchor nuts to be positioned (one on each side) and mark centres for the bolts.

Transfer the bolt hole centres to the front part and, with all 3 mouldings held together with each other, drill the two holes with a 4.8mm drill.

Disassemble the parts and install an MS21047-3 anchor nut under each hole in the leg fairing halves using TAPK33BS rivets. Countersink the rivet holes in the glassfibre first to ensure that the rivets are flush.

Finally, attach the leg fairing halves to the nose gear leg using silicone and bolt the front fairing to them using AN525-10R8 bolts.

Nose Wheel Fairing

The nose wheel fairing is divided in two parts; front and rear. Four bolts fasten the two parts together and a further four bolts secure the fairing assembly to brackets mounted to the fork sides. Refer to figure 2.

Preparation

To provide clearance the front of the leg fairing it is necessary to cut half circles out of both front and rear parts. Trim lines are moulded into the fairings as a guide but initially trim slightly inside of the line and only increase the size of the cut-out after trying them in place. Arrange for a small clearance between the fairings to allow the nose wheel fork to caster in a complete revolution without rubbing.

Mark a centre line for the fastening bolts 10mm (3/8") from and parallel to the rear face of the front fairings. With the two fairing parts held together, drill the four holes for the AN525-10R8 bolts (two each side) with a 4.8mm drill. The lower holes should not be positioned too far around the underside as this would make access to the bolts difficult. Space the two bolts approximately 15cm (5") apart. (Refer to Fig. 2). Install MS21047-3 anchor nuts using TAPK33BS rivets on the inside of the rear fairing's flange, remember to countersink the rivet holes before riveting.

Mounting Brackets



The two vee shaped brackets, SK20, which the nose wheel fairing is bolted to is to be secured to the wheel fork by the axle bolt. Before installation though, the arms of the vee brackets need to be bent outwards from the fork to accommodate the wheel fairing's width and anchor nuts need to be riveted to the ends of the arms.

Firstly, install the unbent brackets onto the wheel fork using the axle bolt. If you are careful, you should be able to extract the bolt and replace it with the brackets without disturbing the wheel, axle and spacers. Refer to the build manual for information on the wheel installation if you do decide to remove it.

Position the rear wheel fairing around the wheel and establish what clearance there is between the brackets and the inside walls of the fairings. You will need to bend the brackets to take up this clearance so remove them from the fork to do this.

Leaving enough of a flat area at the ends of each arm for anchor nuts to be mounted and where the nut and bolt will be at the centre, bend the arms of the brackets sufficiently so that they will touch the inside of the fairing. You will be able to make small adjustments once the brackets are re-installed on the wheel fork, but an off-set of about 15mm (5/8") should be about right.

Whilst the brackets are still off the aircraft, drill the rivet holes for the MS21047-3 anchor nuts but do not rivet them on just yet.

Re-install the brackets onto the nose wheel fork as before and hold the wheel fairing in place making sure that it is level with the aircraft. Reaching inside the fairing, use a short piece of pencil to mark the four hole centres of the mounting brackets. Drill the four holes using a 4.8mm drill.

Finally, rivet in place the four MS21047-3 anchor nuts (on the inside of the brackets remember) using TLPD419BS rivets. You will need to open up the holes in the anchor nuts with a 3.2mm (1/8") drill for the rivets.

The rear fairing may now be bolted in place using AN525-10R8 bolts with AN970-3 washers and the front fairing bolted to the rear fairing, again using AN525-10R8 bolts.

Main Gear



Wheel fairings

The main gear wheel fairings are made up from a front and rear part, with a vertical split line. Four AN525-10R8 bolts fasten the two parts together. The fairings are secured in place around the wheels by two brackets, one which is bolted to the brake torque plate, the other supported by a tube inserted into the hollow axle. See figure 3.

Preparation

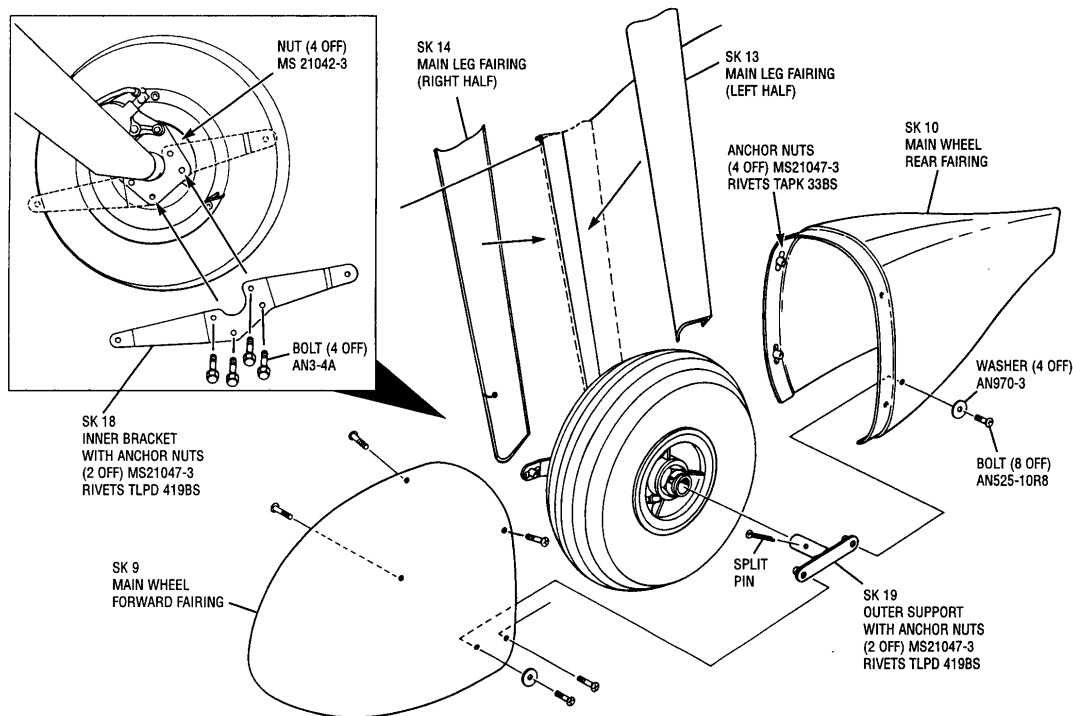

Fig 3. Main Gear Fairings (Port side shown)

Put the two parts of the wheel fairings together, securing them with adhesive tape. Mark hole centres for four bolts, two each side, positioning them such that the holes are approximately 10mm (3/8") from the rear of the front fairing and spaced about 18cm (7") apart. Ensure that you do not position a bolt hole where cut outs will need to be made to accommodate the main gear leg and the brake hose. Drill 4.8mm holes for the bolts and attach MS21047-3 anchor nuts to the rear fairing flange using TAPK33BS rivets. Countersink the rivet holes to allow the rivets to be flush with the flange.



Identify the scribe marks for the cut outs required for the gear leg and brake hose and, making sure that you cut each fairing assembly on opposite sides to each other (one port, one starboard), open up the cut-out checking for fit with the aircraft as you do so.

Bracket Installation

Before the inboard bracket is fitted, the arms of the bracket are required to be bent such that the bolts holes at each end come into contact with the inside face of the fairing. An offset of about 35mm (1.3/8") should be sufficient but slight adjustment may be necessary on final fitting. Remember to bend one bracket the opposite way to the other so that they are handed port and starboard. Leave the end flats sufficiently long to accommodate an MS21047-3 anchor nut (do not fit them at this stage). The central part should remain flat where it is in contact with the brake torque plate. Figure 3 indicates where the bends should be made.

Securing the inboard bracket to the brake torque plate using AN3-4A bolts and MS21042-3 nuts in the two available holes, drill the two other holes required in the torque plate with a 4.8mm drill, using the holes already in the bracket as a guide. Install two more bolts and nuts to secure the bracket and torque plate together, inserting the bolt from the bracket side. It may be necessary to shorten the end of one of these bolts to avoid conflict with the bolt securing the torque plate to the gear leg. Alternatively, you may install this one bolt through from the torque plate side.

Outboard Brackets

The outboard brackets, SK19, are supported by tubes which fit inside the hollow axle. The axle nut's split pin is used to prevent the bracket rotating.

Remove the split pin and axle nut and slide the tube of the bracket into the axle. To establish how far the tube should be inserted, hold the wheel fairing in place so that it is centred around the wheel. The inboard bracket should be in contact with the fairing's inboard face. Move the outboard bracket until it contacts the fairing's outboard face and mark the tube where it emerges from the axle.

Remove the fairing and, with the tube inserted in the axle the correct amount and the bracket arms horizontal, drill through the tube using the split pin hole in the axle as a guide. It may be necessary to remove the wheel to do this.

Having replaced the wheel, if removed, coat the tube of the SK19 bracket with silicone to seal against water ingress and install it, securing it with the split pin.

Securing the Fairings

Whilst installing the main wheel fairings, remember to ensure that they must be positioned such that with the tail of the aircraft in contact with the ground, the fairings should still be clear themselves.

Set the fairings up so that they are level longitudinally and laterally (pitch and roll). Doing this by eye should be sufficient.



Mark where the bracket holes need to be drilled in the fairing then drill these holes with a 4.8mm drill. Drilling one hole for each bracket first is advised. This way you can insert a bolt to line the fairing and bracket up before drilling the second holes.

Before fitting the fairings, scuff sand around each of the four mounting holes and layup 3 plies of “bid” in each position. A 5 x 5 cm (2” x 2”) patch will suffice. After cure drill open the holes.

Attach MS21047-3 anchor nuts to the brackets using TLPD419BS rivets, opening the holes to 3.2mm (1/8”) first. The wheel fairings can now be fitted using AN525-10R8 bolts and an AN970-3 washer.

Main leg Fairings

The main leg fairings are to be attached to the gear legs using silicone only. The front edges butt together on the main gear leg and the trailing edges join together using the flange on the left half of the fairings. Refer to figure 3.

A hole, with a slit into it from the leading edge, is required in the inboard half fairing to allow the brake hose through. Before deciding where the hole should be, trim the ends of the fairings to fit with the fuselage and the wheel fairing. When trimming the upper end leave a gap between it and the fuselage to allow for movement during landing and taxiing. The gap may be filled with silicone or just taped over on installation.

When you are happy that the leg fairings fit properly, apply silicone to the sides of the leg (or the fairing where the leg will be in contact with it) and the trailing edge flange. Feed the brake hose through the slit into its hole and apply silicone to secure it and to stop it chafing. After you have positioned them, you will need to hold the fairings halves together using adhesive tape until the silicone has cured.

If you are likely to operate on muddy surfaces, it would be a sensible addition to add bulkheads in the wheel fairings ahead of and behind the tyre to prevent a build-up of mud collecting in them. Thin plywood, suitably sealed against water or 2 ply bid laminates would serve as bulkhead materials.

Installation of the Speed kit is now complete and the aircraft should be weighed (with all useable fuel pumped out) for new weight and balance calculations to be made. Annotate the log book with the results.