

Cockpit Width Increase

Classification: Optional

Applicability: All Europas

Compliance: N/A

Introduction

This modification provides an increase in internal cockpit width of 30 mm (1.2"). The result is that, in addition to there being an increase in shoulder room, any contact with the fuselage side will be spread over a significantly larger area and so will be more comfortable for the broader occupant. The width increase is achieved by altering the door lower member and the door sill to cause the door seal to be recessed instead of proud.

Preparation

This is best done with the door removed from the aircraft. Cover the window to protect against scratching. Mark out the cut-out lines onto the inside skin of the door according to the dimensions shown in figure 1. Cut out the portion of the inner skin and discard it.

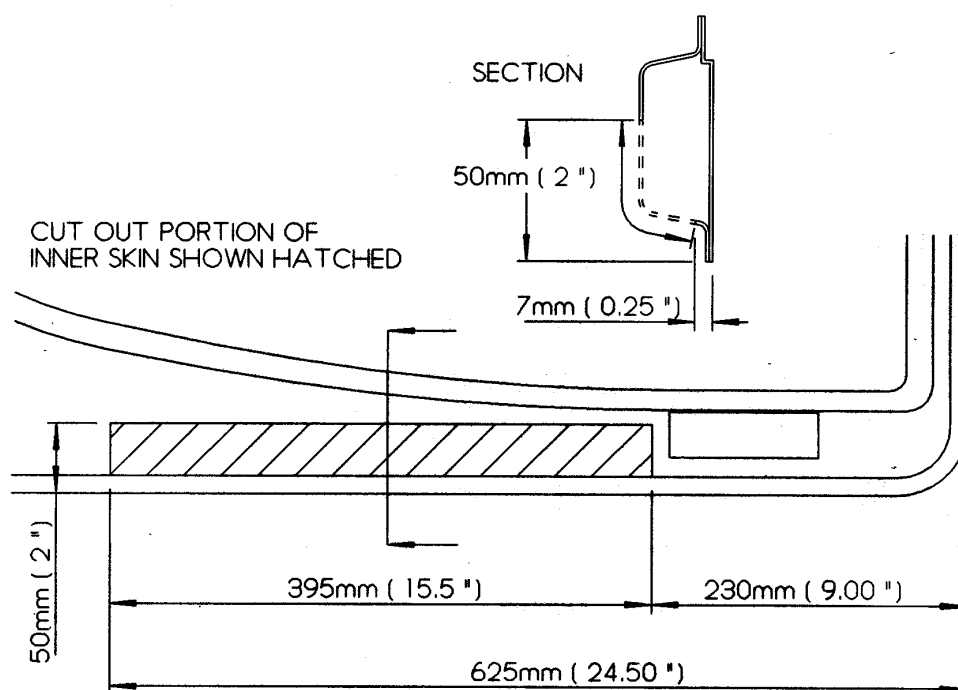

Fig 1. Marking out portion of door for cut-out.



Door Latch System

You will need access to the latch mechanism to replace the rear push-rod, so carefully prise off the latch cover that you bonded in place on the door's inner skin. Careful use of heat may be required here.

It is highly probable that the latch cover will be destroyed on removal, so the recess moulding incorporates the cover. The new moulding also incorporates the latch guard, however if you'd rather retain your original one, this piece may be cut off the moulding and discarded.

Rear push-rod

The recessed lower member of the door that you'll be fitting does not allow room for the rearmost 10mm diameter latch push-rod, so a 10mm x 5mm rectangular bar is to be used in its place.

Remove the original rear push-rod from the doors and check the dimensions between the hole centres. If your measured dimensions differ from those shown in the figure below but your door latches function correctly, make your new push-rods to your dimensions. Otherwise, make the two push-rods for each door according to the drawing in figure 2. You will be relieved to see that these push-rods are far easier to make than the original round section ones.

You'll need to file down the thickness of the push-rod at one end where you'll fit a single-leg anchor nut. Leaving the push-rod at full thickness here would cause the anchor nut to foul inside the door.

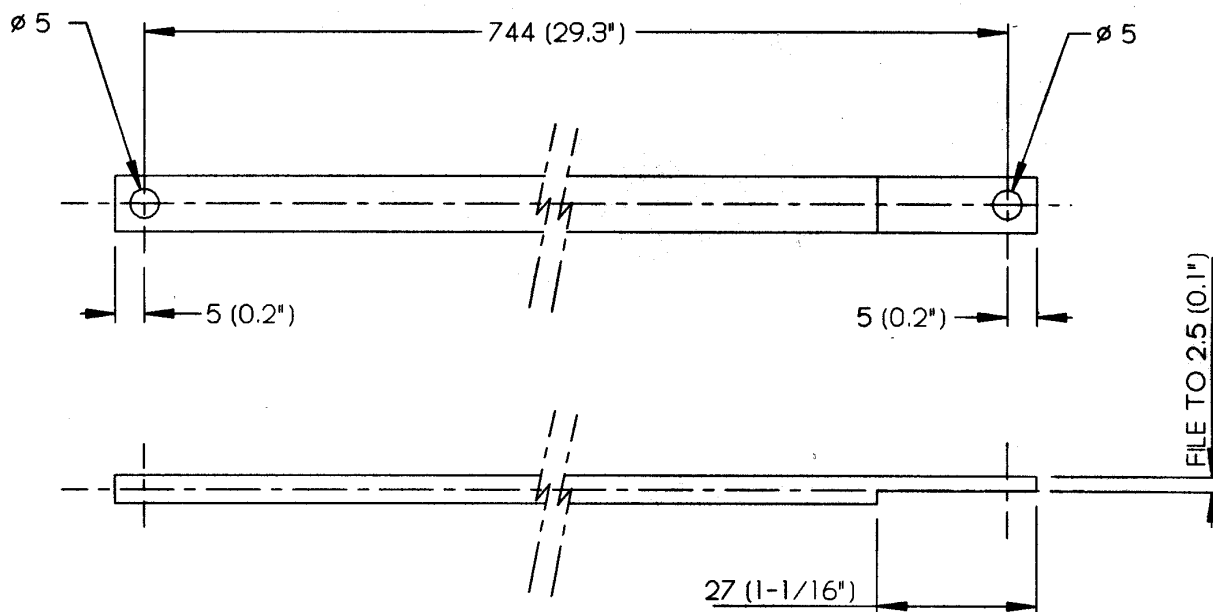

Fig 2. Dimensions in millimetres of rear push rod - 2 required.

Attach one MS21051-3 anchor nut to the recessed end of each push-rod using two TAPK 36BS rivets. See figure 3. Countersink the 2.4mm rivet holes in the unfiled face of the push-rod first. You can do an acceptable countersink by using a drill of around 5mm (3/16") diameter.

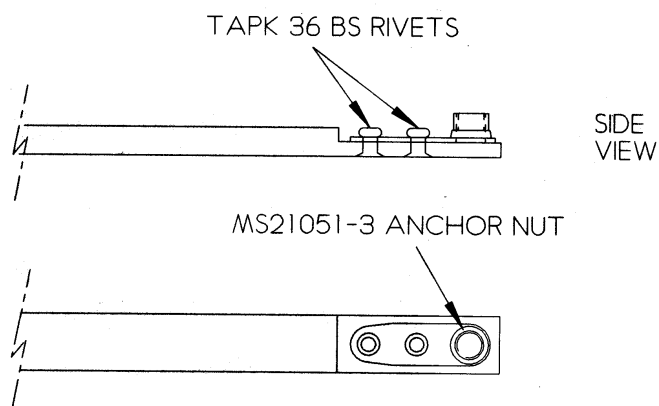

Fig 3. Attachment of anchor nut to push rod.

Substitute the original round rear push-rod with the new rectangular section one, noting that the attachment method at the latch is slightly different from the original method. See fig 4. Tighten the bolt fully, then back it out 1/4 turn to allow the lever and push-rod to rotate freely relative to each other.

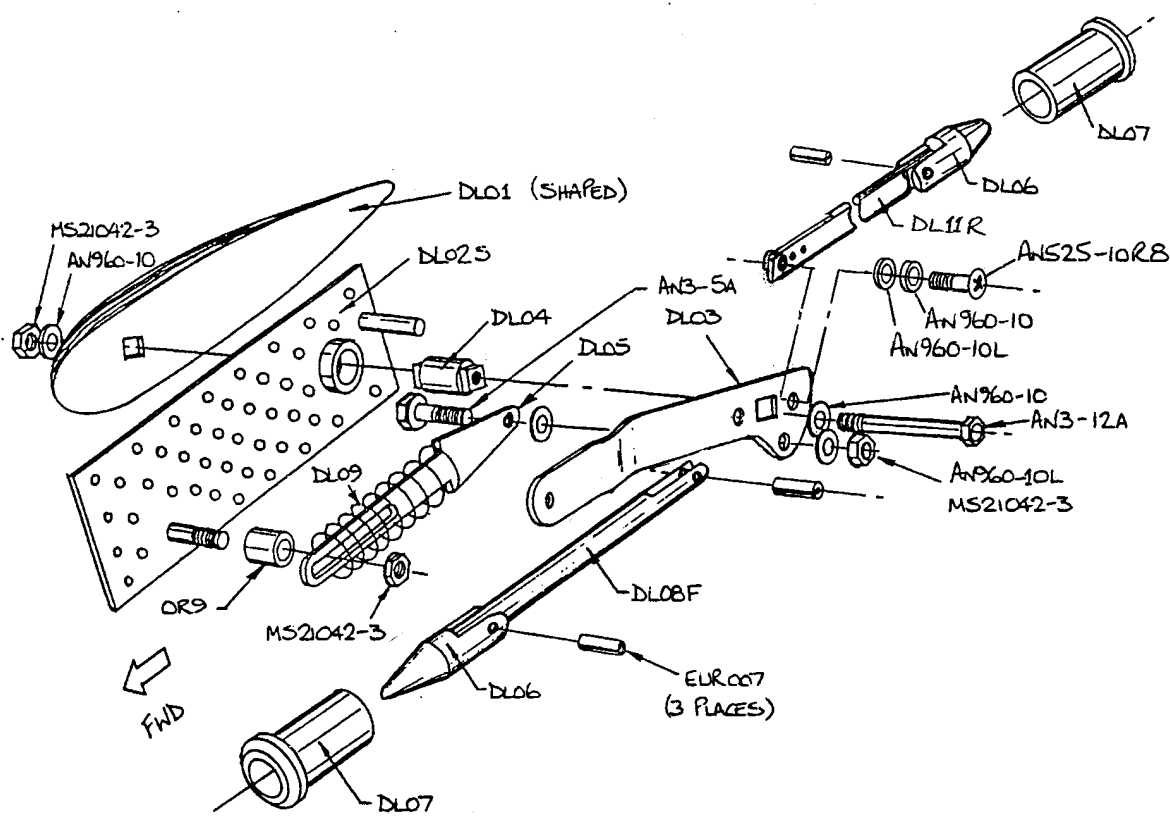

Fig 4. Attachment of rear push-rod.



It may be necessary to bend the push-rod slightly to avoid contact with the recess moulding or to align it better with the shoot bolt or latch lever. Try the recess moulding in place and make any bends in the push-rod as necessary.

Bonding Recess Moulding

The door recess mouldings (F35P and F35S) may require some final trimming. The mouldings should cover only the inner, upper and lower faces of the door's inner skin, so the flanges each side should be trimmed off. Trim to where the radius starts.

Scuff sand the door inner skin around the cut-out in preparation for bonding on the recessed moulding F35P (port) or F35S (starboard); also scuff sand the inside of the moulding where it will contact the door. Thoroughly clean the bond areas. Either epoxy or Araldite 420 mixed with floc may be used. To minimise drips don't use an excessive amount of adhesive.

Apply the adhesive to the edge of the cut-out of the door, wipe a thin smear on the bond area of the recess moulding then position the recess moulding (F35P or F35S) to the door.

Door sill modification

Removing original seal flange

The vertical flange of the door sill locates the seal, so this needs to be modified to allow the seal to follow the door's newly recessed portion.

To avoid a butt type joint between the original sill flange and the newly shaped flange (this would prevent the seal from fitting) you will lay up the new flange using a disposable splash mould F36P or F36S. The splash mould locates around the lower portion of the door aperture and is held in place using good adhesive backed tape.

Referring to figure 5, mark out the portion of the flange to be cut off, then cut away the marked out portion, and adjust the cut-out to accommodate the appropriate splash mould. See also the photograph in figure 6.

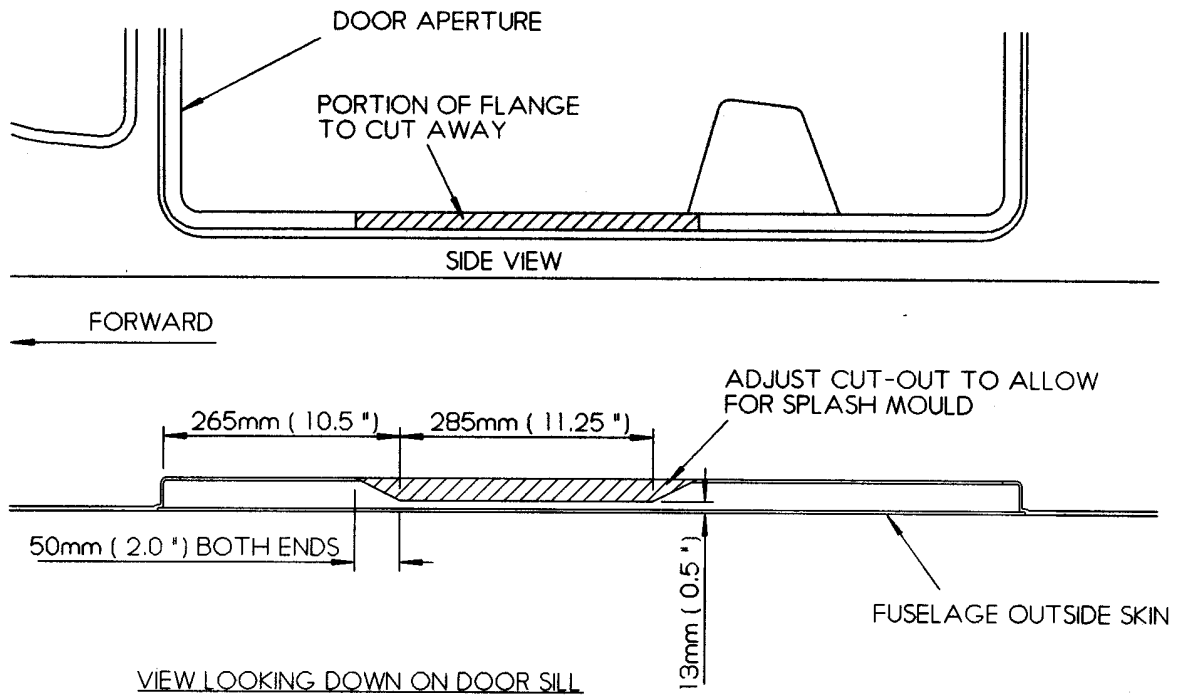

Fig 5. Cutting out the door sill.



Fig 6. Photo of cut away flange.



Chamfer the edges from the underside to enable a splice joint to be made. See figure 7.

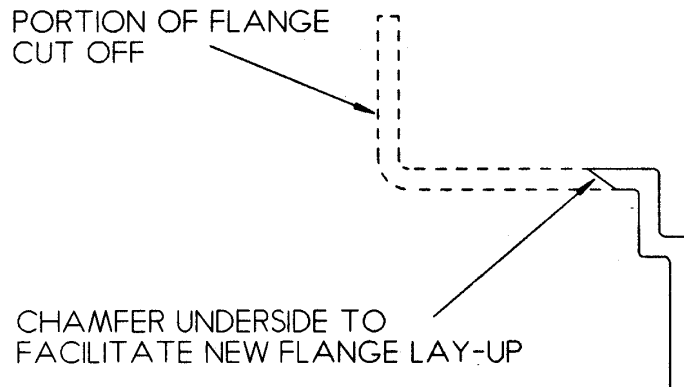

Fig 7. Detail of chamfer.

Laying up new flange

Scuff sand the underside and forward and aft areas of the sill. Using polished wax or any other suitable release agent, prepare the mould surface of the splash mould and install it on the sill using adhesive backed tape to hold it securely.

Cut 8 pieces of 'bid' cloth 45cm x 10cm (18" x 4"). Lay up all 8 plies of 'bid' cloth onto the splash mould and surrounding door sill, overlapping at least 25mm (1") onto the existing sill.

After cure, remove the splash mould and trim the flange top edge to align with the original flange. Sand away the overlapping portion of the new flange only where the door seal clips over it, leaving only a scarf joint here. See figure 8.

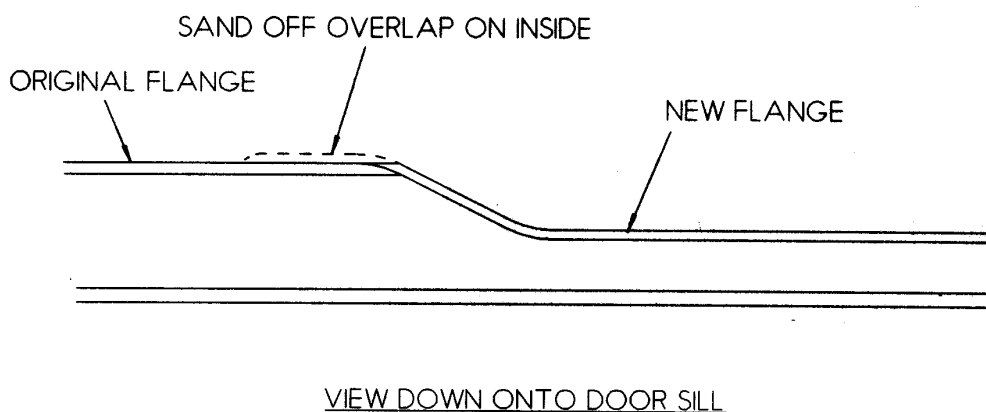

Fig 8. Sanding away excess material.

The door seal may now be applied.