



Wing Levelling Autopilot Mod 75

TITLE : Installation of Wing levelling Auto-pilot
(Navaid Devices, Trio, TruTrak).

APPLICABILITY : All Europa variants
Mod Type : During build or Retro-fit

1. Introduction

The addition of a wing levelling auto-pilot to the aircraft provides the benefits of allowing the pilot to concentrate on airmanship and lookout and preventing unintended deviation from course while undertaking in-cockpit tasks such as map reading.

Each of these autopilots uses a dedicated controller which will continue to function if other aircraft systems fail. This Modification is specific to the single axis (roll) wing levelling auto-pilot. This is connected to the aileron torque tube beneath the starboard seat. General instructions are given below. A separate appendix is provided for each type highlighting issues specific to that type.

Before commencing work read the entire modification instructions and obtain a current copy of any applicable local regulations.

UK builders will require the LAA Inspection Checks LAA/IC-APWL (available from the LAA web site). If you wish to deviate from these instructions including use of a different controller or servo to those detailed, you must consult LAA Engineering.

2. Parts List

Qty	Part No.	Description	Source
1	CS03	bush	Mod 75 Kit
1	CS36	Actuator arm	Mod 75 Kit
4	AN3-4A	Bolt, Servo to aircraft	Mod 75 Kit
4	AN970-3	washer servo to aircraft	Mod 75 Kit
6	MS10242-3	Nuts	Mod 75 Kit
6	TLPD440BS	Pop Rivets	Mod 75 Kit
4	TLPD424BS	Pop Rivets	Mod 75 Kit
1	CLIP1	Jubilee clip	Mod 75 Kit
4	EUR 069	Safety Washers	Mod 75 Kit
2	AN3-7A	Bolts rod end to arm	Mod 75 Kit
1	Loctite 243	Thread locking compound	Mod 75 Kit
4	AN3-3A	Bolt, servo to mount (TruTrak)	Mod 75 kit
4	AN960-10	Washer servo mount (TruTrak)	Mod 75 Kit
	Other Parts		
	GPS unit	With NMEA output	Better than 1 output per second Autopilot supplier
	Controller/Servo	See appendix	
	Mounting kit	See appendix	Autopilot supplier
	Composite	92125 Bid and Ampeg 20	Stock
		Araldite 420+ Flox	Stock

See the manufacturer's documentation for recommended GPS units and connection details.

List of related Drawings / Photo's

Drawing No.	Title / Description	Issue
Mod 75/1	Access hole location, Trio & TruTrak	2
Mod 75/2	Actuator arm installation, Trio & TruTrak	2
Mod 75/3	Servo installation TruTrak	3



Wing Levelling Autopilot Mod 75

Mod 75/4	Servo installation Trio (Navaid)	3
Picture 1	General view (TruTrak)	1
Picture 2	Servo and connector (TruTrak)	1
	Manufacturer's installation instructions	

3 Action

3.1 **Servo Installation Overview.** This makes use of the inboard passenger thigh locker. The servo control crank is linked to an actuator arm attached to the aileron torque tube that runs underneath the passenger seat with a link rod working through a hole in the thigh support rib of the locker. The hole must be made large enough to allow for the movement of the push-rod when full aileron in both directions is applied, with additional 3-6mm (1/8" - 1/4") clearance around. The analogue servos require the arm to be repositioned (See appendix 2 & 3). For general layout see picture 1 and drawings. The arm attachment bolt(s) must be re-installed with thread locking Loctite, such as Loctite 243.

3.2 **Access Openings.** The access openings are made as per the drawing in the appropriate appendix. Position the inboard access hole relative to actual position of the seat rib. The outboard hole should be centred over the torque tube. Cut the servo access first and ensure the servo will fit in the position indicated. Remove about 5-10mm (1/4" - 3/8") of the foam core between the skins around the access holes and fill with epoxy/flox to reinforce the edges. Covers MUST be made and fitted to these access holes.

3.3 **Actuator Arm (CS36).** The arm (CS36) is attached to the aileron torque tube by a CS3 bush. Bond and rivet the arm to the CS3 bush, using TLPD440BS rivets and Araldite 420. If fitted during construction the unit can be slid onto the torque tube complete. If the control system is already installed in the cockpit module, the CS03/CS36 must be split in half longitudinally to be fitted, on the centre line of the torque tube. Make the cut fine a cut as possible. Trial fit the assembly to the torque tube with the Bonding/Jubilee clip (CLIP1).

3.4 **Servo Installation.** The servo (and bracket if TruTrak) is bolted to the thigh support rib with the AN3-4A bolts. Cut the hole in the rib to allow the actuator rod to pass through. Cut the rod to length and trial fit the servo to ensure the rod is horizontal and at right angles to the torque tube. Adjust the position of the components as required. When correct install the AN3-4A bolts, AN970-3 washer and MS10242-3 nuts. (For TruTrak see Appendix 1)

3.5 **Actuator Arm fixing.** Finalise and check the position of all components. Mark the intended position of the TLPD424BS rivets as far around the side as possible to avoid the pitch push-rod running inside the aileron torque tube (see section on drawing 10507/2). Check that these positions are accessible for both drilling and riveting. This may require the use of a long drill and/or a "long nose" rivet puller. Remove the arm assembly and drill the rivet holes. Remove all coating and roughen the torque tube. Bond the assembly in position with 420 and flox. Ensure the longitudinal joint line is full of 420 and flox. Install the Jubilee clip to hold in position. When cured, drill the torque tube **making sure not to touch the pitch push-rod that runs inside it with the drill** and insert four rivets to hold the assembly on the torque tube. The clip may be removed to aid riveting but should be replaced.

3.6 **Push Rod.** The control rod must be cut to length and assembled with the rod-end bearings. The method varies slightly by type (see appendix 1 and 3). **The rod end bearings must be locked to the control rod (with AN345-10 nuts) and a safety washer fitted.**

3.7 **Controller Instrument Installation.** The instrument may replace the turn co-ordinator, attitude indicator or be installed separately in a new position on the panel. Check that your intended installation meets the requirements of LAA/IC-APWL. (see Appendix 1 and 3)

3.8 **Disconnect switch.** A disconnect switch is required to be fitted which is easily accessible from either seat. This may be incorporated in joystick-mounted switches or on the panel.



Wing Levelling Autopilot Mod 75

3.9 **Wiring.** See the wiring diagram in the manufacturer's documentation. All wiring must be properly insulated and supported. (For Trutrak see Appendix 1)

4 Weight and Balance

	Weight (lb/kg)	CG (in/mm)	Moment
Existing A/C			
+/- Weight Change	+2 lb	52 in	104 lb.in
Post Mod A/C			

Amend the aircraft weight and balance schedule accordingly.

5 Flight Test and Special Instructions

5.1 The following instructions are designed to ensure compliance with the UK LAA requirements set out in Inspection Checklist (LAA/IC-APWL). Different or additional requirements may be applied by other authorities.

5.2 Specific ground and flight test instructions are given in the manufacture's documentation. These MUST be carried out fully. In particular:-

- 1) Make sure the servo is operating in the correct sense.
- 2) Make sure the servo can be overridden manually.
- 3) Make sure that there is no possibility for the servo crank to reach an angle relative to the push-rod to cause over-centre geometric lock or otherwise jam.
- 4) Make sure that, should the servo arm become detached, the push-rod or servo arm cannot cause an aileron control jam.

5.3 LAA inspector to check the completed work, sign off the checklist, raise a log-book entry including reference to Factory Mod 75, update weight schedule and issue PMR (Permit Maintenance Release).

5.4 Return to LAA Engineering the completed inspection checklist with request for flight test authorisation. Note: Before receipt of flight test authorisation – PFRC (Permit Flight Release Certificate) - the modified aircraft may only be flown if the push-rod between the servo and aircraft control system is removed.

5.5 With valid PFRC, conduct flight test according to flight test schedule LAA/FT-APWL.

5.6 Return to LAA Engineering completed flight test schedule.

Notification of final approval will be sent to the applicant. Until this is received, the aircraft may only be flown if the push-rod between the servo and aircraft control system is removed.



Wing Levelling Autopilot Mod 75



Picture 1 Example TruTrak installation. Looking down through access holes in thigh support.



Picture 2 Example TruTrak installation. Looking aft through front face of thigh support.



Wing Levelling Autopilot Mod 75

Appendix 1 TruTrak

This Modification is specific to the single axis (roll) TruTrak digital Servomotor driven by one of the following TruTrak controllers:-

- a) TruTrak EFIS
- b) Digitrak (digital display of ground track)
- c) Pictorial Pilot (replaces turn co-ordinator)
- d) ADI Pilot 1 (replaces attitude indicator)

The TruTrak servo is a slow speed digital stepper motor and is inherently safer than the analogue motor and clutch use by other designs. Unlike the analogue servos the centre (Null) is not fixed and can be anywhere.

See also three drawings at the end of this modification document.

2. Parts List

Qty	Part No.	Description	Source
1	Controller	See list above	TruTrak Flight Systems 1500 S Old Missouri Road Springdale Arizona, AR 72764-1157
1	DSB B	Digital Servo	
1	EUR-R	Mounting kit & Arm	

3. Additional/Alternative Actions. Read with main sections.

3.4 **Servo Installation** Check that the servo arm retaining screw has been replaced (see service bulletin 21/01/2009). If not remove the servo arm retaining screw and re-install it with Loctite 243 or a suitable equivalent. If this screw is ever removed in service, it must be re-installed using Loctite 243 or a suitable equivalent. The servo needs to be bolted to the TruTrak bracket with AN3-3A bolts and AN960-10 washers provided.

3.6 **Push Rod**. The control rod must be cut to length and assembled with the rod-end bearings. A new thread will need to be cut in the control rod with a 10 x 32 UNF tap. The rod-end bearings can then be assembled. **The lock nuts and safety washers must be fitted.**

3.7 **Controller Instrument Installation**. The Pictorial Pilot and ADI Pilot 1 replace the turn co-ordinator or attitude indicator respectively. The Digitrak will require a new position on the panel. Check that your intended installation meets the requirements of LAA/IC-AP.

3.9 **Wiring**. To avoid accidental damage, The supplied "D" type connector shell should be modified to keep the wiring within the seat base (see picture 2).



Wing Levelling Autopilot Mod 75

Appendix 2 Navaid Devices

See also three drawings at the end of this modification document.

2. Parts List

Qty	Part No.	Description	Source
1	AP1	Controller	Navaid Devices Inc. 641 North Market Street Chattanooga, Tennessee 37405
1	S2	Servo	
1		Mounting kit & Arm	
?	Smart Coupler II	Converter	

In July 2008 Navaid Devices ceased trading. New systems and parts may be unobtainable. If unit replacement is required the Trio system is largely compatible.

The S2 servomotor is driven by the AP1 controller. The Smart Coupler II digital to analogue converter may be required with some GPS units.

3. Additional/Alternative Actions. Read with main sections.

3.1 **Servo Installation Overview.** This analogue servo has a fixed centre (Null) and the actuator arm must be repositioned through 90 degrees in this installation. The arm retaining screws must be installed with Loctite 243 or a suitable equivalent.

Appendix 3 Trio

See also three drawings at the end of this modification document.

2. Parts List

Qty	Part No.	Description	Source
1	Controller	EZ Pilot	Trio Avionics 1840 Joe Crosson Drive, Ste. A1 El Cajon California 92020
1	Gold Servo	Servo	
1		Mounting kit & Arm	

The Trio "Gold Servo" is an improved design that can be used as a direct replacement for the Navaid S2 servo. It can be supplied with a mounting base identical to the S2 (-A) or a Trio version which is slightly larger (-B).

The EZ Pilot controller can be used to control the Gold Servo or the original Navaid S2 servo.

3. Additional/Alternative Actions. Read with main sections.

3.1 **Servo Installation Overview.** This analogue servo has a fixed centre (Null) and the actuator arm must be repositioned through 90 degrees in this installation. The arm retaining screws must be installed with Loctite 243 or a suitable equivalent.

3.6 **Push Rod.** The control rod must be cut to length and the tapped insert riveted in place. The rod-end bearings can then be assembled. **The lock nuts and safety washers must be fitted.**

3.7 **Controller Instrument Installation.** The EZ Pilot may replace the turn co-ordinator or be installed as an additional instrument. Check that your intended installation meets the requirements of LAA/IC-AP.

TruTrak

Section B - B ← Section A - A
Virtual Intersection with front seat face

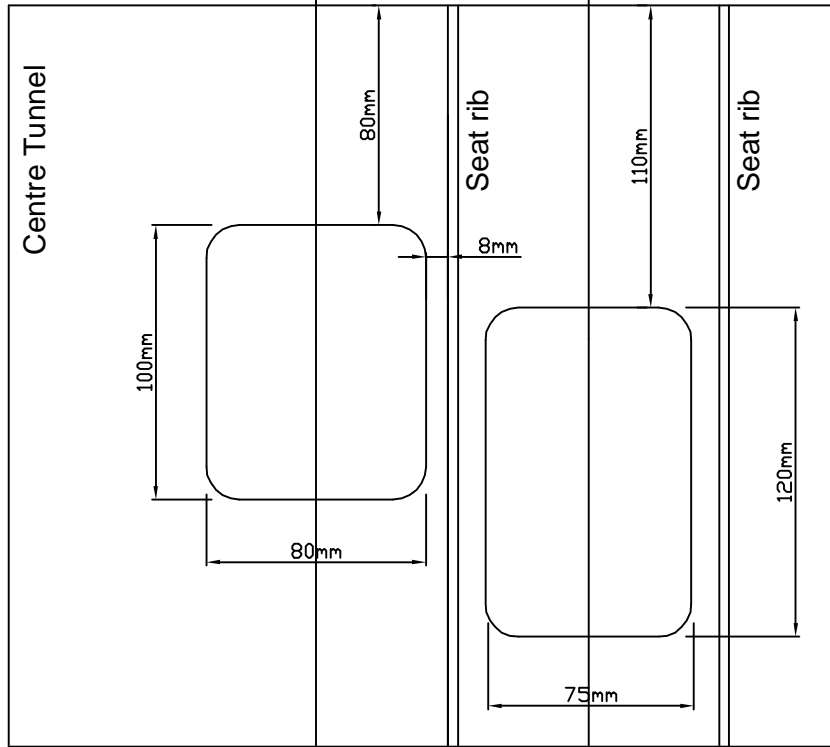

Trio (Navaid)

Section B - B ← Section A - A
Virtual Intersection with front seat face

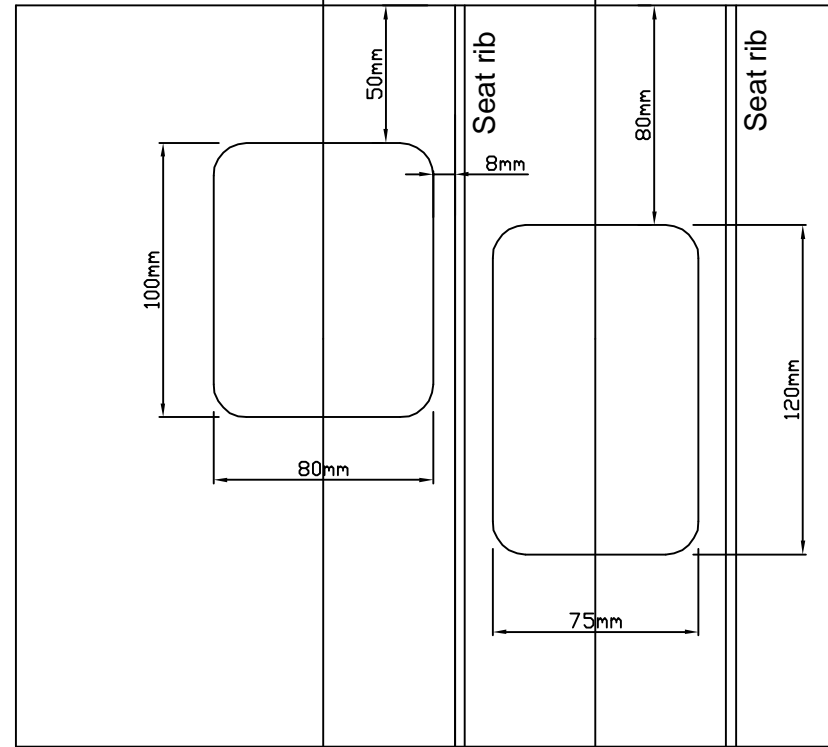

Notes

- 1) This view is perpendicular to the slope face of the seat
- 2) Position the inboard access hole relative to actual position of the seat rib.
It needs to be need to be <8mm from the rib to allow access the bolt head.
- 3) The outboard hole should be centred over the torque tube.
- 4) Covers **MUST** be made and fitted to these access holes.
- 5) Remove the foam core around the access holes and fill with epoxy/Flox.

Europa Aircraft (2004) Limited				
Drawn By I. F. Rickard	Title Europa XS & Mono Trio & TruTrak Autopilot - Cutouts			
Date 19/02/2010				
Checked by	PFA A/C Type Europa XS	Serial No 247-13714	Drawing No Mod 75/1	Rev 2
Date	Scale 1:2.5	A/C Regn G-IANI	Drawing Sheet	1 of 1



**Wing Leveler Autopilot
Mod 75**

Mod 75

REV	Drawn By	Date	Description

Section A - A

CS36 Actuator Arm

Material - 2024-T3 3.2mm sheet
Also Acceptable - HS30FT & 6082-T6

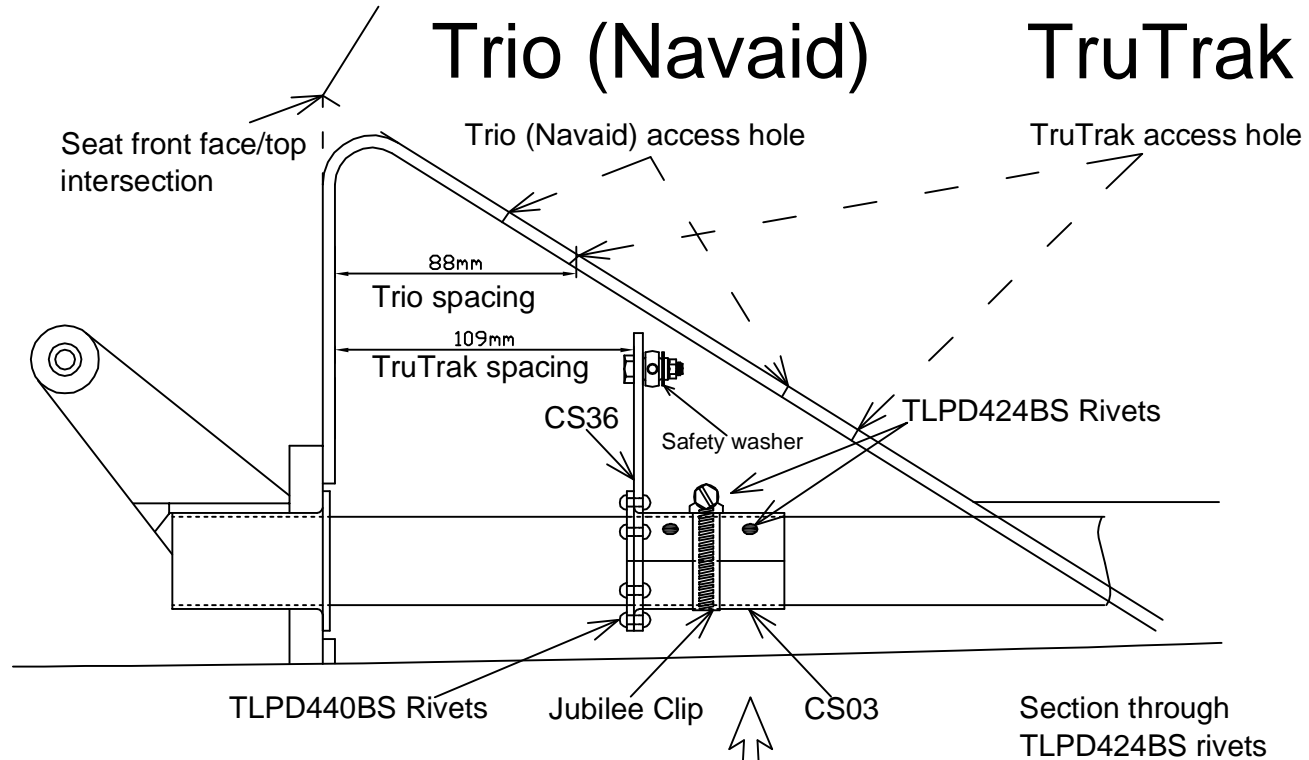
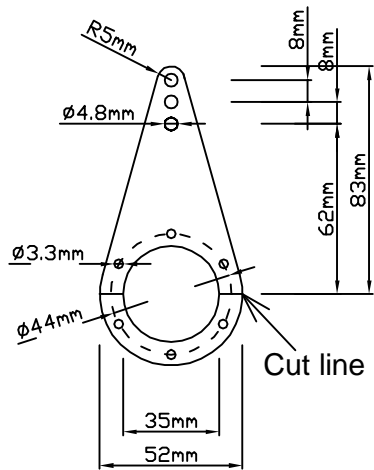

Notes

- 1) Relieve the inside edge of the actuator arm so that it sits flush to the face of the CS03
- 2) Glue and rivet (TLPD440BS) the actuator arm to the CS03
- 3) Split the assembly horizontally on the centre line of the torque tube. Make the cut as fine as possible
- 4) Clean and roughen the torque tube and glue the assembly in position with 420 and flox. Install the jubilee clip to hold in position.
- 5) When cured, drill and insert four rivets (TLPD424BS) to hold the assembly on the torque tube. The clip may be removed to aid riveting but should be replaced.



Wing Leveler Autopilot
Mod 75

Europa Aircraft (2004) Limited				
Drawn By I. F. Rickard	Title Europa XS & Mono			
Date 19/02/2010	Trio & TruTrak Autopilot - Actuator arm			
Checked by	PFA A/C Type Europa XS	Serial No 247-13714	Drawing No Mod 75/2	Rev 2
Date	Scale 1:2.5	A/C Regn G-IANI	Drawing Sheet	1 of 1

Mod 75

REV	Drawn By	Date	Description

Section B - B

NB The servo arm retaining screw must be installed with Loctite 243.

TruTrak

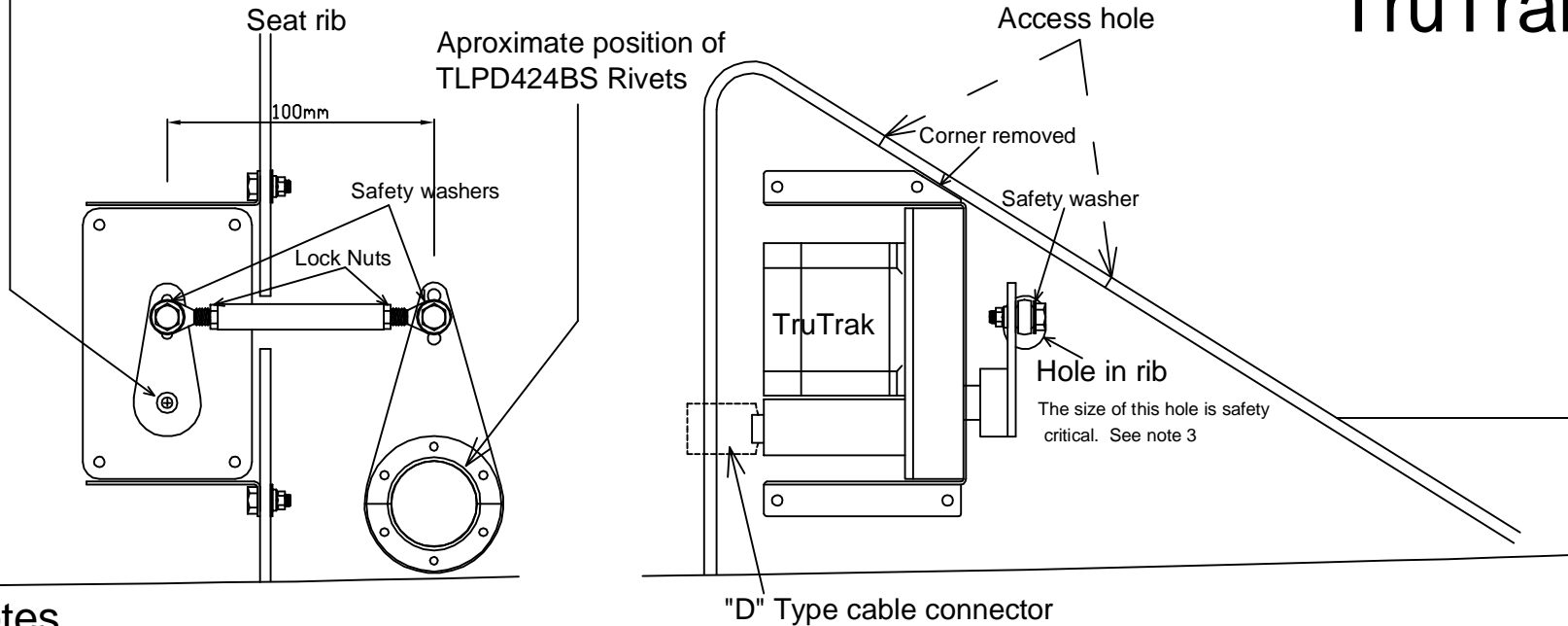

Notes

- 1) Cut aft corner of mounting bracket to match seat angle. This will remove existing hole. Drill new mounting hole.
- 2) When installed it MUST NOT be possible for the arms to go "over centre".
- 3) Check that the aileron control system cannot be jammed at any position throughout its full range (wings rigged) with the servo arm detached from the servo and the push-rod sliding in the hole through the rib. Check this also with the push-rod disconnected from the control arm and the servo crank in turn.
- 4) Ensure four safety washers are used on the two ball ends.
- 5) Ensure lock nuts are installed on the drive rod ends.
- 6) Cut the "D" type connector shell to prevent it projecting beyond the face of the seat.

Europa Aircraft (2004) Limited				
Drawn By I. F. Rickard	Title Europa XS & Mono TruTrak Autopilot - Servo			
Date 19/02/2010	PFA A/C Type Europa XS	Serial No 247-13714	Drawing No Mod 75/3	Rev 3
Date 22/04/2009	Scale 1:2.5	A/C Regn G-IANI	Drawing Sheet 1 of 1	

Wing Leveler Autopilot
Mod 75

Section B - B

REV	Drawn By	Date	Description

NB The servo arm retaining screws must be installed with Loctite 243.

Trio (Navaid)

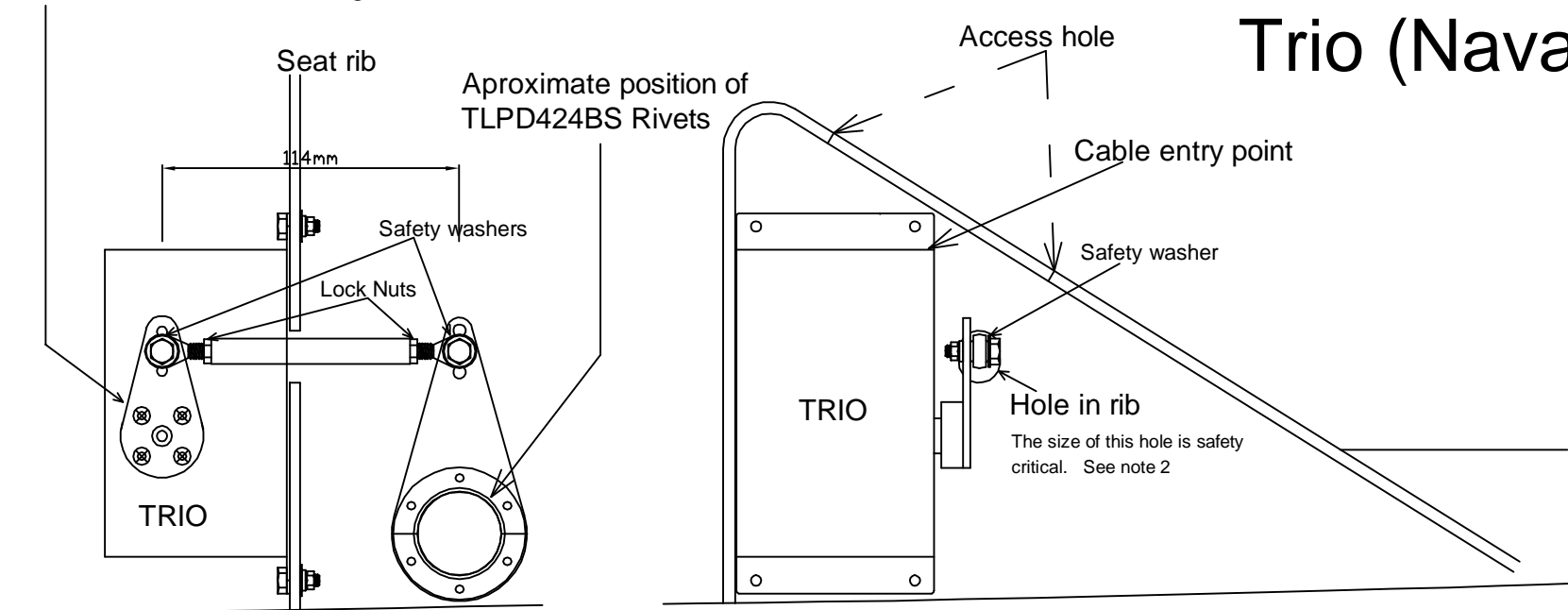

Notes

- 1) When installed it **MUST NOT** be possible for the arms to go "over centre"
- 2) Check that the aileron control system cannot be jammed at any position throughout its full range (wings rigged) with the servo arm detached from the servo and the push-rod sliding in the hole through the rib. Check this also with the push-rod disconnected from the control arm and the servo crank in turn.
- 3) Ensure four safety washers are used on the two ball ends.
- 4) Ensure lock nuts are installed on the drive rod ends .

Europa Aircraft (2004) Limited				
Drawn By I. F. Rickard	Title Europa XS & Mono Trio Autopilot - Servo			
Date 19/02/2010				
Checked by	PFA A/C Type Europa XS	Serial No 247-13714	Drawing No Mod 75/4	Rev 3
Date	Scale 1:2.5	A/C Regn G-IANI	Drawing Sheet	1 of 1



Wing Leveler Autopilot
Mod 75