



Europa Aircraft Co

OWNERS MANUAL

AFFIX PHOTOGRAPH
OF YOUR AIRCRAFT HERE

Aircraft Registration

Europa Construction Number



Europa Aircraft Co

Published by **Europa Aircraft Co.**

Ltd.

Unit 2a, Dove Way, Kirby Mills Industrial Estate
Kirkbymoorside, North Yorkshire, YO6 6NR, England

No part of this manual may be reproduced in any form without the prior written permission of the publisher.

Copyright © August 1998 by Europa Aircraft Co. Ltd
All rights reserved

Printed in Great Britain

WARNING : This manual is obsolete unless updated by newsletters 20 and onwards. Mandatory flight safety improvements may be included so do not fail to do this. Remember, the responsibility is yours.

OWNER'S DETAILS	
Built by

Operator



Table of Contents

Title page

Table of contents

List of revisions

Three view drawing

Section 1 Introduction

Section 2 Limitations and placards

Section 3 Emergency procedures

Section 4 Rigging and de-rigging

Section 5 Normal operations

Section 6 Weight and balance

Section 7 Initial systems check

Section 8 Service and maintenance

Section 9 Flight testing procedures

Section 10 Safety information

Section 11 Pilot experience requirement

Section 12 Performance



Europa Aircraft Co

INTENTIONALLY BLANK

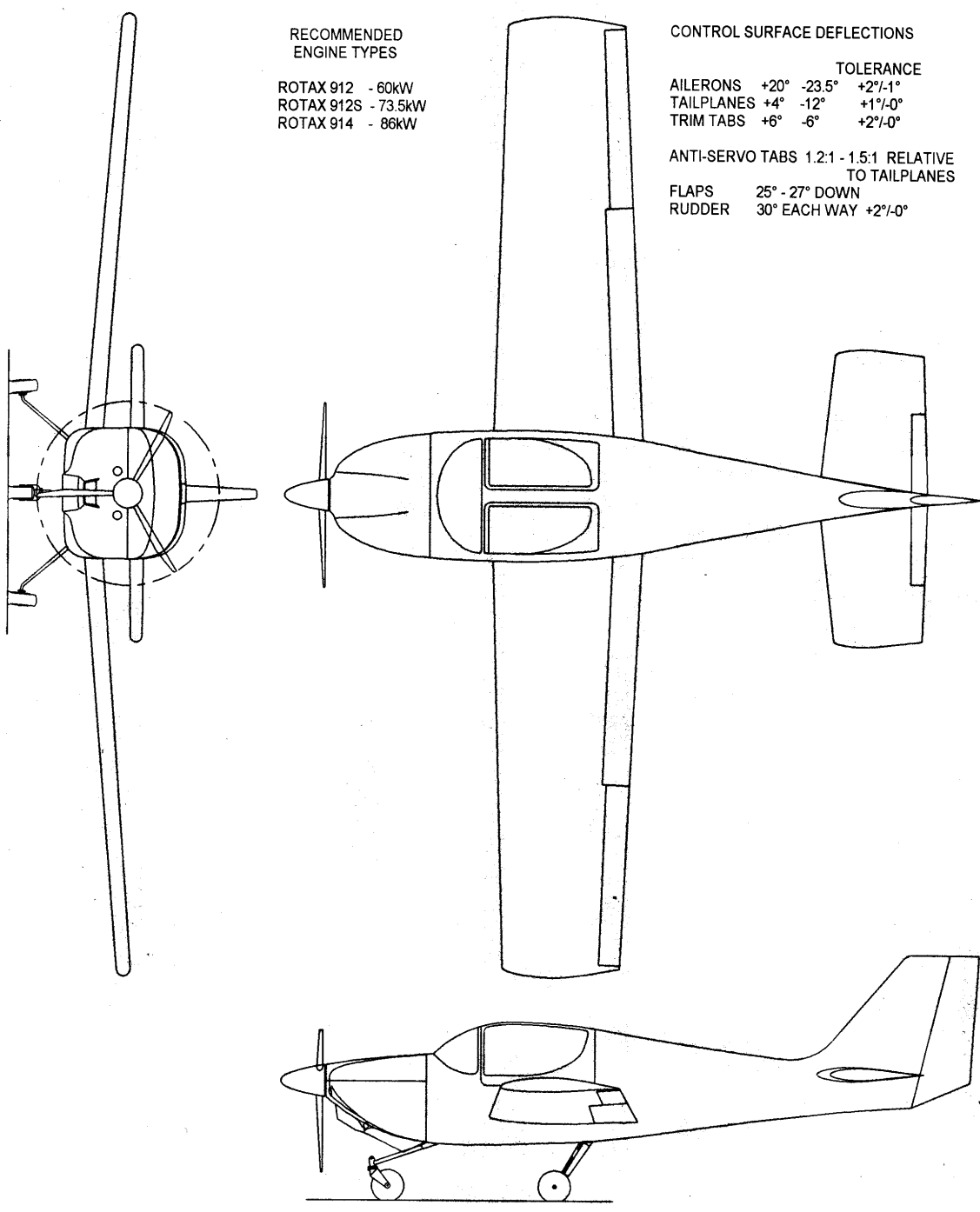

RECOMMENDED
ENGINE TYPES

ROTAX 912 - 60kW
ROTAX 912S - 73.5kW
ROTAX 914 - 86kW

CONTROL SURFACE DEFLECTIONS

	TOLERANCE	
AILERONS	+20° -23.5°	+2°/-1°
TAILPLANES	+4° -12°	+1°/-0°
TRIM TABS	+6° -6°	+2°/-0°

ANTI-SERVO TABS 1.2:1 - 1.5:1 RELATIVE
TO TAILPLANES

FLAPS 25° - 27° DOWN
RUDDER 30° EACH WAY +2°/-0°



Section 1	Introduction
------------------	---------------------

The purpose of this manual is to explain how to operate your Europa aircraft safely.

General description

The Europa is a modern two seat, high performance homebuilt aircraft which uses the latest aerodynamic design in wing sections and composite construction techniques. The Europa tri-gear is designed to be an efficient touring aircraft with safe handling characteristics. By incorporating a 3 blade propeller and efficient exhaust silencer system the Europa complies easily with all international noise requirements for light aircraft.

A purpose built transporter can be used so that the aircraft may be quickly rigged and de-rigged for storage at home. The Europa tri-gear has non-retractable main and nose gear. The flaps are electrically operated, and can be set to any position between zero and full flap (30°).

Principal Features and Dimensions

- | | |
|-------------|---|
| * Engines | Rotax 912 - 80 bhp / 60 kW |
| | Rotax 912S - 100 bhp / 73.5kW |
| | Rotax 914 - 115 bhp / 86kW |
| * Wing span | 27 ft 2 in (8.28 m) |
| * Wing area | 100ft ² (9.30 m ²) |



Europa Aircraft Co

* Wing root chord	50"	(1.27m)
* Wing tip chord	40"	(1.02m)
* Aspect ratio	7.0	
* Length	19 ft 8"	(6.00m)
* Height	7 ft 0"	(2.13 m)
* Tailplane span	8 ft	(2.44 m)
* Tailplane area	22 sq ft	(2.05m ²)
* Fuselage width	44"	(1.12 m)
* Baggage capacity	80 lb	(36 kg)
* Gross weight	1370 lb	(622 kg)
* Wing loading	13.7lb/ft ²	(67kg/m ²)
* Main wheel tyres	5.00 x 5	
* Nose wheel tyre	11 x 4.00 - 5	
* Fuel capacity	15 Imp gall	68 litres

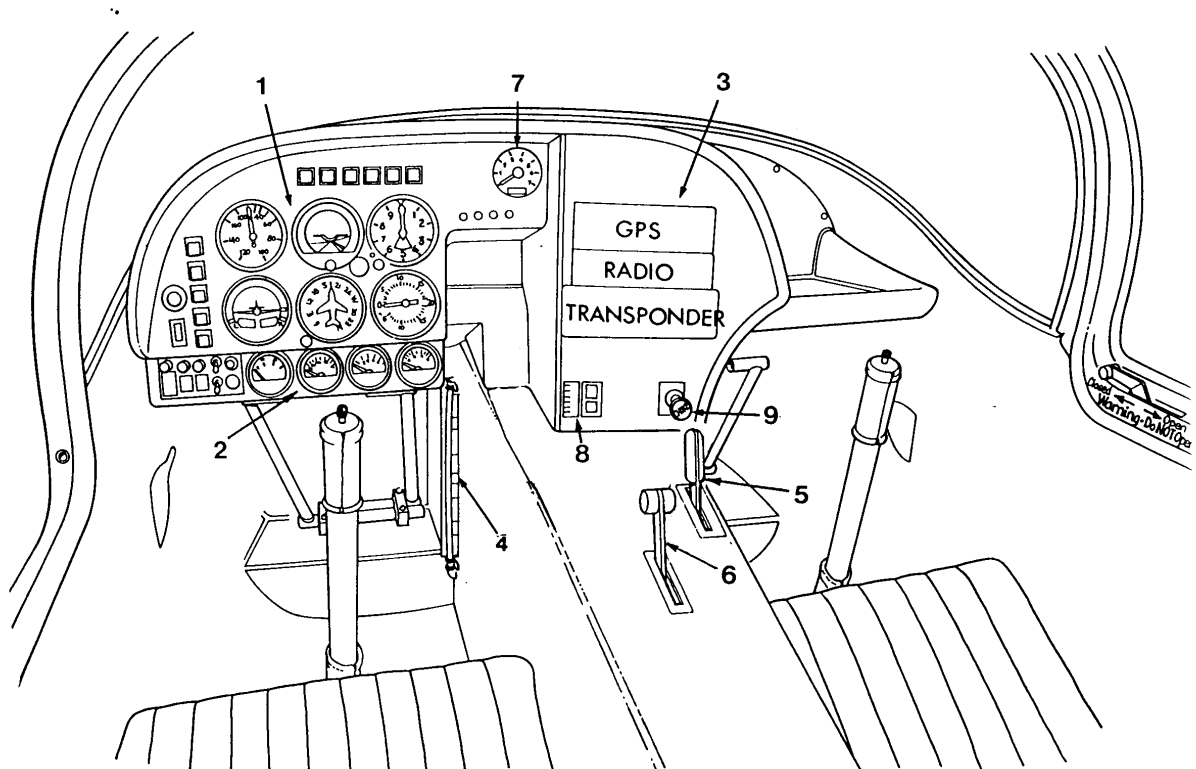

Figure 1 - 1 Cockpit Layout

- | | |
|------------------------|--------------------------------|
| 1. Flight Instruments | 6. Throttle |
| 2. Engine Instruments | 7. Engine R.P.M.. |
| 3. Radio/Nav Equipment | 8. Pitch Trim Switch and Gauge |
| 4. Fuel Sight Gauge | 9. Choke |
| 5. Wheel Brake | |



Important Notice

This manual is not designed, nor can it serve as a substitute for sufficient and competent flight instruction. It is not intended to be a guide of basic flight instruction nor a training manual.

This manual should be read thoroughly by the owner/operator/pilot to become familiar with the operation of the aircraft. It is intended to serve as a guide under most circumstances, but cannot take the place of good sound judgement during operation. Multiple emergencies, adverse weather, terrain, etc. may require deviation from the recommended procedures.

The owner and operator of an aircraft should be familiar with government regulations applicable to the operation and maintenance of an aircraft.

All airworthiness directives (ADs) issued against an airframe, engine or propeller must be complied with.

Flying itself is not inherently dangerous, but to an even greater extent than any other mode of travel it is terribly unforgiving of any carelessness, incapacity or neglect.

The builder/pilot is entirely responsible for the manufacture, maintenance, inspection, flight test and normal operation of the aircraft. Therefore, thorough, careful procedures must be carried out at all times.

How well the aircraft is built, maintained and operated will determine how safely it performs. Maximum performance and safe operation can only be achieved by a skilled pilot and good mechanic. Thorough, careful construction, continued maintenance and practice during operation are essential.



Performance data in this manual is based on data collected on Europa aircraft operated by Europa Aviation Ltd. Many factors affect aircraft performance - build quality, maintenance standards, propeller settings, builder modifications, pilot techniques etc., etc..

The aircraft operator/pilot should carefully measure and record the performance of their aircraft to assist in the safe operation of their particular aircraft.



Europa Aircraft Co

INTENTIONALLY BLANK



Section 2	Limitations and Placards
------------------	---------------------------------

Limitations

* Never Exceed Speed (V_{ne})	165 kts	(305 kph)
* Manoeuvring speed (V_a)	97 kts	(179 kph)
* Max. Structural Cruise Speed (V_{no})	131 kts	(243 kph)
* Max. Flap/gear extension speed (V_{fe})	83 kts	(154 kph)
* Structural limit loads (1370lb)	+3.8g/-1.9g	

Placards

- ⌘ Intentional spins prohibited.
- ⌘ No smoking in or near aircraft.
- ⌘ Flight in icing conditions prohibited.
- ⌘ Canopy warning: do not open in flight.
- ⌘ Registration letters / numbers and name and address of registered owner (To be engraved on a stainless steel plate).
- ⌘ Occupant warning: This aircraft has not been certificated to an international requirement.
- ⌘ Daytime VFR only. (Depending on nationality.)
- ⌘ Throttle FULL IDLE



Europa Aircraft Co

- ✘ Pitch trim indicator NOSE UP NOSE DOWN
- ✘ All circuit breakers/fuses and switches to be placarded.
- ✘ CONNECT PITOT/STATIC (To be positioned on seat back.)

Airspeed Indicator Markings

- ✘ White arc 44 — 83 kts
(full flap operating range)
- ✘ Green arc 49 — 131 kts
(normal operating range)
- ✘ Yellow arc 131 — 165 kts
(operate with caution - only in smooth air)
- ✘ Red line 165 kts
(maximum speed for all operation)

Engine limitations

Refer to engine operating and maintenance manual, supplied by engine manufacturer.



Weight limits

- ✕ Maximum take off weight 1370lb
- ✕ Maximum landing weight 1370lb
- ✕ Maximum baggage weight 80lb
(Refer to weight and balance section 6).

Centre of gravity limits

- ✕ Forward limit 58.0" aft of datum
- ✕ Aft limit 62.5" aft of datum

The fore and aft reference datum is a position 29.25" forward of the rear edge of the cowling joggle in the fuselage moulding.

Symbols, abbreviations and terminology

- * **CAS** **Calibrated airspeed** is the indicated airspeed of an aircraft, corrected for position and instrument error. Calibrated airspeed is equal to true airspeed in standard atmosphere at sea level.
- * **KCAS** **Calibrated airspeed** expressed in knots.
- * **GS** **Ground speed** is the speed of an aircraft relative to the ground.
- * **IAS** **Indicated airspeed** is the speed of an aircraft as shown on the airspeed indicator.
- * **KIAS** **Indicated airspeed** expressed in knots.



Europa Aircraft Co

- * **TAS** **True airspeed** is the airspeed of an aircraft relative to the undisturbed air which is the CAS corrected for altitude, temperature and compressibility.

- * **V_a** **Manoeuvring speed** is the maximum speed at which application of full available control inputs will not over stress the aircraft. This speed is also used as a rough air speed in turbulence.

- * **V_{fe}** **Maximum flap extended speed** is the highest speed permissible with the flaps in a prescribed extended position.

- * **V_{ne}** **Never exceed speed** is the speed limit that may not be exceeded at any time.

- * **V_{no}** **Maximum normal operating structural cruising speed** is the speed that should not be exceeded except in smooth air, and then only with caution.

- * **V_{s1}** **Stalling speed** is the minimum steady flight speed at which the aircraft is controllable, with flaps retracted.

- * **V_{s0}** **Stalling speed** is the minimum steady flight speed at which the aircraft is controllable with flaps extended.

- * **V_x** **Best angle of climb speed** is the airspeed which delivers the greatest gain of altitude in the shortest possible horizontal distance.

- * **V_y** **Best rate of climb speed** is the airspeed which delivers the greatest gain in altitude in the shortest possible time.



SECTION 3

EMERGENCY PROCEDURES

Fire

There are normally only three sources of aircraft fire, electrical, fuel and oil.

In the event of fire on the ground shut off all electrical power and fuel supply and evacuate the aircraft taking with you the carbon dioxide type fire extinguisher that should be fitted to the aircraft. For in flight fire, determine the cause:

If electrical - switch all electrical power **off**.

If fuel, switch both fuel and electrics - **off**.

If an oil fire is suspected then initially slow the aircraft sufficiently to stop the propeller from windmilling, and so stop the oil pump, before resuming the best glide speed.

Engine failure

Modern aircraft engines of the type fitted to the Europa are extremely reliable. Catastrophic failure without any warning is most unlikely. Pilot induced failures on the other hand are quite common.

Running out of fuel, mistaking mixture and carburettor heat control, complex fuel management tasks and carburettor icing are but a few causes for engine stoppage. The Rotax engine as fitted to the Europa does not require a separate carburettor heat lever nor does it have a mixture control (other than the choke for cold starting).



Europa Aircraft Co

The design intentions have been to cut engine management/pilot workload to a minimum.

Pilots should regularly monitor the condition of the engine during flight. A gradual or partial loss of power, rough running, increasing oil or cylinder head temperature, electrical discharge, lowering oil pressure or increased mechanical noise and vibration could be a signal that all is not well and that a precautionary landing should be made.

If the engine stops- *Don't panic*. The first and most important rule in **any** emergency in the air is

FLY THE AIRCRAFT
keep control.

Every year lives are lost because pilots lose control of the aircraft (stalled or spun in) whilst experiencing what was possible a relatively minor emergency. The Europa has good speed stability so even if you become inattentive the aircraft should maintain the selected attitude and speed, providing it is in trim. If the engine stops:

- * **TRIM FOR 75 Kts**
- * **FUEL PUMP ON - SELECT RESERVE**
- * **CHECK IGNITION ON BOTH**
- * **ASSESS HEIGHT**



If engine will not restart.

Always land into wind if possible. Do not try to stretch your glide - better to land a little fast on a touchdown point of your choosing than to stall into a hedge or wall. In other words - it is better to hit the far hedge at 20 kts than to stall into the near one at 45 kts.

Evacuate the aircraft as soon as possible.

Engine failure after take off (EFATO)

If the engine fails soon after the aircraft has left the ground on take off, lower the nose immediately to maintain flying speed and prepare to land straight ahead. Slight turns can be made to avoid obstacles. Only if enough altitude is available can a 180° turn be made to return to the airfield.

You are much more likely to survive an emergency landing following an EFATO by landing straight ahead than a stall and spin resulting from a steep, slow turn back to the field. Only if there is time and you have maintained control of the aircraft should you try to restart the engine.

NOTE: *If engine stoppage was due to fuel starvation and the engine restarted after selecting the reserve setting land within 15 minutes.*

Be prepared for a greater rate of descent with a dead engine as opposed to one on idle power.

Glide in the clean configuration (flaps up) to achieve best glide range. With flaps down and the use of side slipping, high rates of descent can be achieved.



In-flight canopy opening

If a canopy opens in flight it will most likely depart the aircraft. If it does not, do not lose control of the aircraft whilst trying to close it.

Ditching

Flaps should be down to give minimum speed and cushion impact. Landing into wind on the back of a swell is best, or along a trough if that is not possible.

Regularly practice all emergency procedures because you never know when you will need them.



Europa Aircraft Co

INTENTIONALLY BLANK



SECTION 4	Rigging and de-rigging
------------------	-------------------------------

The Europa was designed from the outset to be easily rigged and de-rigged for storage at home. A specially designed transporter will facilitate ease of operation.

The wings of the Europa can be removed leaving the fuselage standing on its undercarriage. This de-rigging is useful if hangar space or door width is limited.

Refer to figure 1 and the subsequent description to aid understanding how the wings are attached to the fuselage.

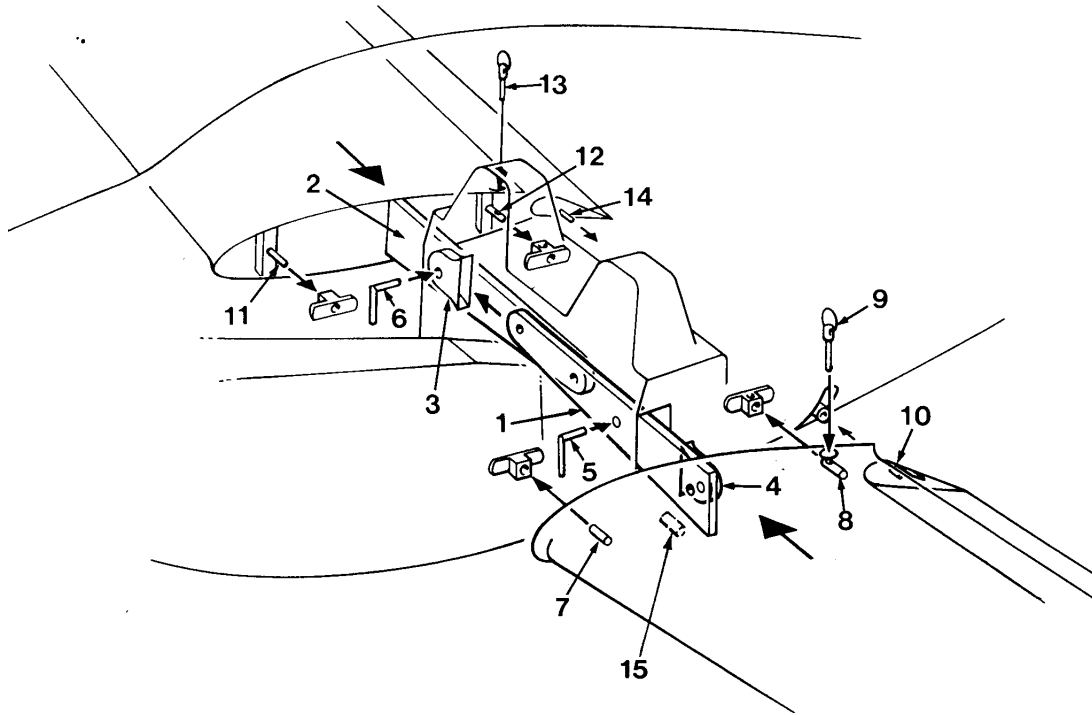

Fig 1. Wing rigging.

- | | |
|-----------------------------|-----------------------------------|
| 1. Port wing spar | 9. Pip pin. |
| 2. Starboard wing spar. | 10. Flap pin inspection point. |
| 3. Port spar socket. | 11. Forward lift pin (starboard). |
| 4. Starboard spar socket. | 12. Aft lift pin (starboard). |
| 5. Spar pin (port). | 13. Pip pin. |
| 6. Spar pin (starboard). | 14. Flap pin inspection point. |
| 7. Forward lift pin (port). | 15. Pitot/static connect |
| 8. Aft lift pin (port). | |



The main wings are held in place by two 1/2" dia pins that pass through both wing spars and the fuselage seat back bulkhead. These pins take the wing bending loads.

Two 12mm diameter pins, fitted to the wing root forward and aft ribs, locate in receptacles on the fuselage sides to lift the fuselage and take torsional loads.

1/4" pip pins are inserted vertically through the rear 12mm pins and receptacles to take the wing drag loads in the cruise and also the forward lift loads at high angles of attack.

There are 12mm diameter pins in the root ribs of the flaps and these locate into bearings on the ends of the flap operating drive tube in the fuselage. *An inspection hole is cut in the inboard top skin of the flaps so that proper location with the controls can be verified during rigging and preflight inspection.*

Ailerons self connect by use of a bellcrank on the wing root rib which mates with a similar bellcrank fitted to the fuselage. Steel locator boxes are fitted to encapsulate the ends of the spars making rigging simpler by holding the wing in position to allow the pins to be engaged.

Rigging

Before rigging inspect:-

- ✘ both wings and controls for damage and correct operation.
- ✘ wing pins and pip pins for damage or corrosion.
- ✘ aileron and flap connect parts for damage and correct operation.



Europa Aircraft Co

- ✘ fuselage sides where the wings mate for damage.
- ✘ wing pin receptacle for damage and corrosion.
- ✘ pitot/static connection tubes for damage.

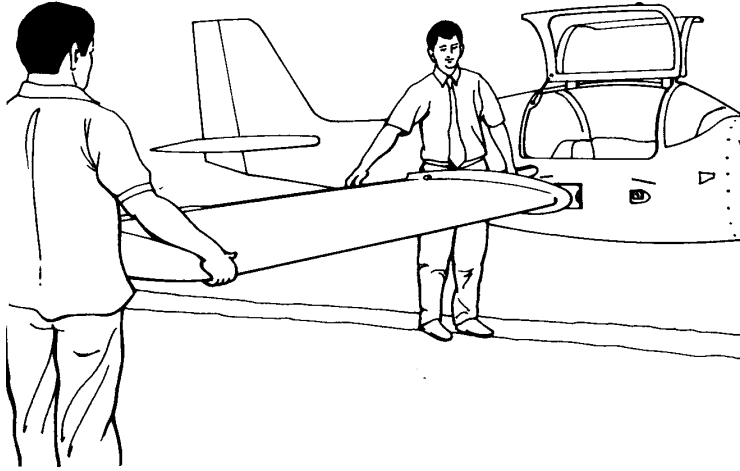

Rigging starboard wing shown.

Note: *Rigging the wings is a two person operation*

With the fuselage supported upright slide the port wing part way into the fuselage, and connect the pitot/static tube connections. Then slide the wing fully home. Witness marks on the fuselage adjacent to leading and trailing edges will help with correct wing incidence alignment.

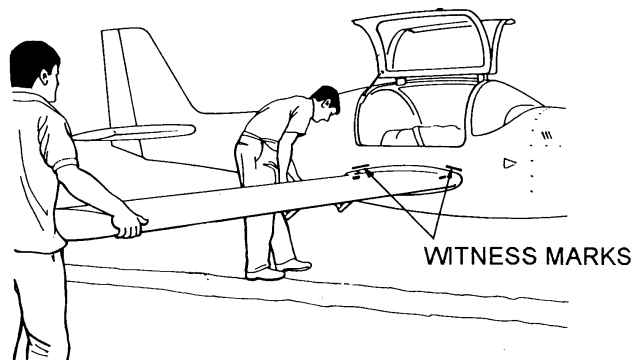



As the wing is being pushed in make sure that the flap drive pin connects and that the front and rear wing pins also locate in their sockets.

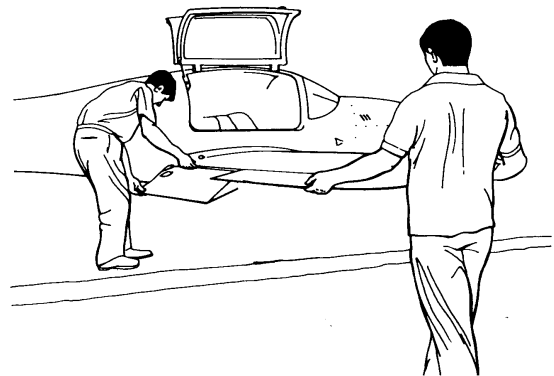
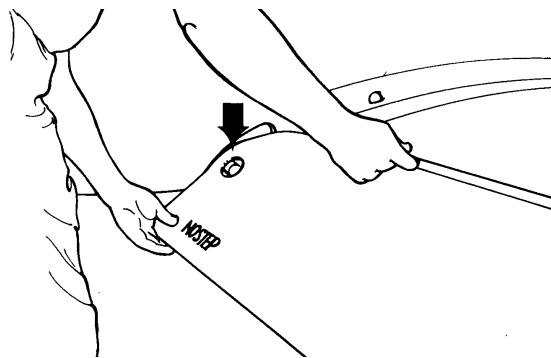

Once fully home insert the 1/2" main pins through the seat back approximately 1" and insert the 1/4" pip pin vertically through the rear 12 mm pin and receptacle. Ensure it springs back into the locking position.

In a similar manner engage the starboard wing, push the 1/2" pins in the seat back bulkhead fully home, and latch.

De-rigging the wings is the reverse of rigging.



Tailplanes

The tailplanes, port and starboard, engage on the tailplane torque tube that passes through the rear of the fuselage, and are held in place by 1/4" pip pins. The tailplane is driven by two 1/4" drive pins which locate into bushes built into the tailplane inboard rib. The anti-servo/trim tab drive is also located into the drive tube passing through a slot in the fuselage sides.

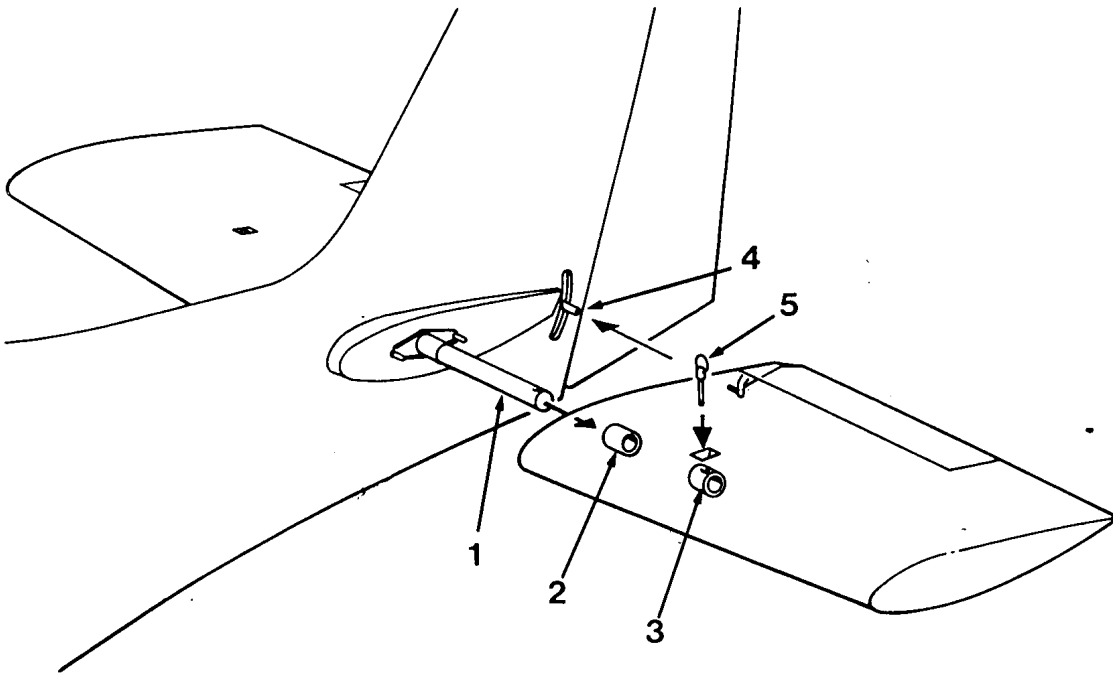

Fig 2. Tailplane rigging.

- | | |
|---------------------------|-------------------------------|
| 1. Torque tube. | 4. Anti servo/trim tab drive. |
| 2. Inner bush (built in). | 5. Pip pin. |
| 3. Outer bush (built in). | |



Rigging the tailplanes

Inspect the individual tailplane for damage. Inspect the tailplane torque tube for damage, scoring or corrosion. It should be kept well greased. A plastic tube can be slid over it for ground handling and to stop dust from sticking to the grease.

Warning: *Take care when sliding the tailplane onto the tube, make sure that they are supported until the tube contacts the outer bush in the tailplane - avoid using any force.*

Hold the tailplane as shown, holding the anti-servo/trim tab from flapping around.

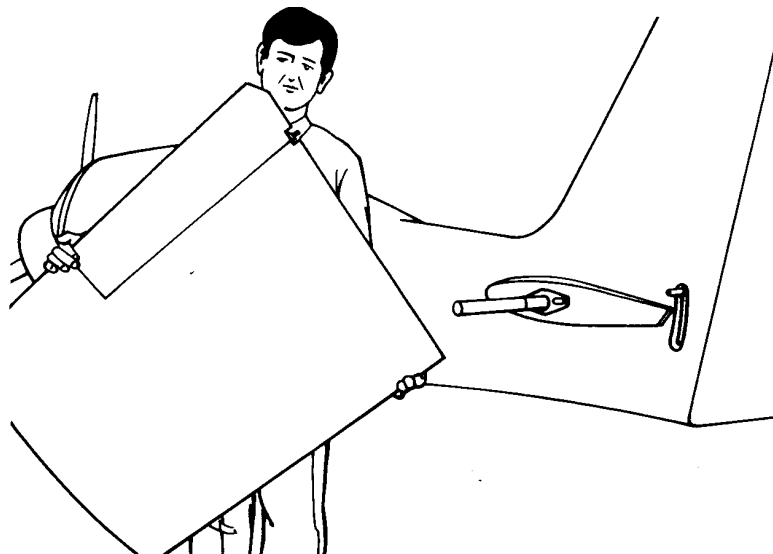



Europa Aircraft Co

Sliding the tailplane onto the torque tube vertically enables better control to ensure the torque tube engages the outboard bush.

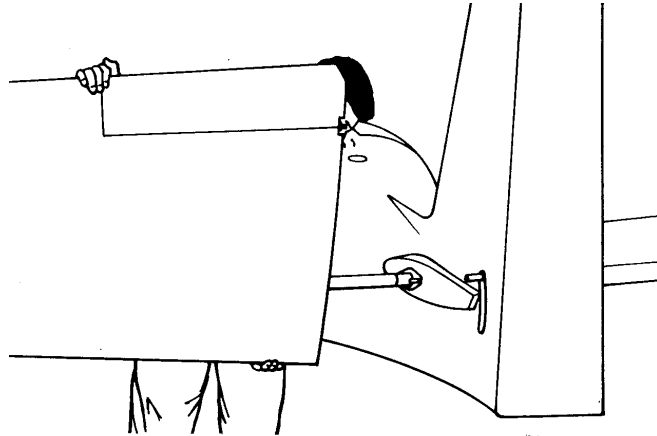

Make sure that as the tailplane drive lugs engage into the tailplane inboard rib, the anti-servo/trim tab drive lugs also engage in the appropriate sockets.

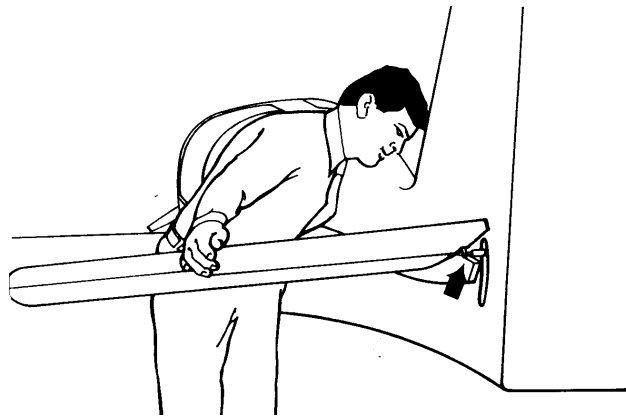

Engage 1/4" pip pins to secure tailplanes and ensure the plunger springs back into the locking position.

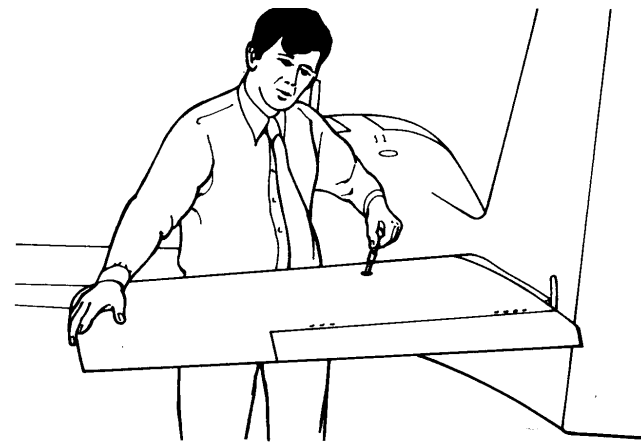

De-rigging the tailplanes is the reverse of rigging, however, it would be good practice to rotate them to their maximum trailing edge up position before removing the first tailplane and so prevent the mass balance weight from crashing down onto its stop once the drive pins disengage.



SECTION 5 Normal operations

Introduction

This section describes the normal operating procedures for both ground and flight operations. All pilots should be thoroughly familiar with this section and the Emergency Procedures, Operating Limitations, Initial Systems check-out, Flight test procedures and Performance data before attempting any ground or flight operations.

Recommended Speeds

* Best rate of climb speed (V_y)	75 Kts	139 kph
* Best angle of climb speed (V_x)	61 Kts	113 kph
* Glide speed (engine off)	75 Kts	139 kph
* Stall speed (flaps up)	49 Kts	91 kph
* Stall speed (flaps down)	44 Kts	81 kph

Pre-flight Walk Around

Cockpit

1. Throttle closed
2. Master switch off
3. Ignition switches off (both)



Europa Aircraft Co

4. Fuel on - main tank
5. Main wing pins engaged and locked.
6. Fuel drains (if fitted) check clear of water.

External port side

1. Remove all tie downs and control locks and stow.
2. Main gear wheel tyre for creep, condition, inflation.
3. Brake brake pad wear, caliper secure.
4. Door and latch check for correct operation and freedom from cracks.
5. Flap check operating pin engaged – hinge points for damage.
6. Aileron condition and operation, free from backlash.
7. Upper and lower wing skin free from stress cracks, fractures and buckles.
8. Pitot/static tube clear – no damage.
9. Inboard forward and aft wing pins engaged into fuselage socket. Pip pin in and secure. Check pip pin spring action.



Engine and propeller

Check:-

1. All cowling attachment screws secure.
2. Engine oil and water quantities, inspection hatches secure.
3. Exhaust tailpipe secure.
4. Water radiator clear from obstructions, damage and chafing.
5. Propeller condition free from cracks or damage.
6. Spinner secure and free from cracks.
7. Rotate engine through four blades to check that no engine oil hydraulic locking is present.

Note: *Always treat an aircraft propeller as live.*

Nose gear

1. Nose wheel tyre for creep, condition, inflation.
2. Nose leg condition.



External starboard side.

- | | |
|--------------------------------------|---|
| 1. Main gear wheel | tyre for creep, condition, inflation. |
| 2. Brake | brake pad wear, caliper secure. |
| 3. Windscreen and door | Plexiglas for cleanliness and freedom from cracks. |
| 4. Starboard wing skin | for cracks, fractures and buckles. |
| 5. Aileron | condition and operation. |
| 6. Flap | check operating pin engaged – hinge points for damage. |
| 7. Door and latch | for correct operation. |
| 8. Inboard forward and aft wing pins | engaged into fuselage socket. Pip pin in and secure. Check pip pin spring action. |
| 9. Rear fuselage skin | for cracks, fractures or buckling. |

Tailplanes

- | | |
|-------------------------|--|
| 1. Tailplanes attached | pip pins engaged and sprung back to locked position. |
| 2. Anti-servo/trim tabs | connected. |



- | | |
|-------------------|---|
| 3. Tailplane | check full and free movement, balance, and correct tab operation (tailplane trailing edge up – tab trailing edge up). |
| 4. Rudder and fin | for cracks and fractures. |
| 5. Rudder | hinges and push-rod attachment. |

Entrance is gained to the cockpit from the trailing edge of the wing. A step area on the wing is provided to assist in the safe entry/exit of the aircraft.

Cockpit

Check:-

- * Fuel selector valve to “**MAIN**”.
- * Glass fuel in-line filter(s) for water and contamination.
- * All instruments and controls for damage.

Note: *Always brief passenger to step off the wing towards the tail on departing the aircraft, never forward towards the propeller.*

The gull wing doors are supported on gas shock struts in the open position. The aircraft may be taxied in calm conditions with the doors open where large power inputs are *not* necessary. In gusty or soft, wet grass conditions where large power inputs are necessary to start the aircraft moving it is prudent to close the canopy. This is also wise in dry dusty conditions when dry grass and debris may be blown into the cockpit area by the propeller.



Pilot position

The Europa is designed to accommodate pilots up to 6'4" (1.93m) in height in comfort. Shorter pilots can fly the aircraft but they must sit on cushions to bring their eye level up to that of a tall pilot.

Note: *When seated in the Europa **all** pilots must have a maximum clearance of (2.5cm) 1" between the top of their heads and the canopy.*

This is necessary to give the best view over the nose for the taxi/take off and landing. Being just 5cm (2") lower than optimum makes a large difference in the field of view over the nose.

Rudder pedal position is set during the build process but to bring the pedals further aft for pilots with shorter legs a small cable adjuster can be fitted onto the rudder pedal cables in the rear of the fuselage.

Seat belts

Four point harnesses are provided for safety with a simple press to release operation similar to many motor cars. These are fully adjustable and should be tight, particularly in the take off and landing stages of the flight.

Door latch operation should be checked before flight and clearly placarded on both the inside and outside of the door showing the open and closed position and a warning "Do not open in flight".

Engine starting

Engine starting on the Rotax engines is both simple and straightforward.



Cold start

1. Brake parking brake on (if fitted)
2. Check clear ahead and behind.
3. Master switch on.
4. Ignition both on.
5. Throttle exercise, then set closed.
6. Electric fuel pump (912) on for 3 seconds, then off.
(914) one pump on.
7. Choke pull and hold full on.
8. Call "CLEAR PROP".
9. Starter engage.

Check oil pressure rises within 8 seconds.

Close choke gradually, increasing throttle to maintain engine RPM and warm engine at 2,000 rpm. for 2 minutes, then at 2500 rpm.

Park into wind and check each ignition circuit at 4000 rpm. Maximum drop with one circuit inoperative 300 rpm. Maximum differential 115 rpm.

Hot start

Same as cold start but *do not* use choke. Opening the throttle slightly may help during hot starts.



Note: Refer to Rotax engine handbook for engine operating limitations and placard accordingly.

Pre-take off check list (vital actions)

1. Trim set for take off (neutral)
 2. Throttle engine idling smoothly.
 3. Choke control full in (off).
 4. Fuel - contents sufficient for flight and reserves.
 - selector Main tank
 - pump (912) on, (914) both pumps on.
 5. Flaps check 18° down.
 6. Hatches (doors) closed and latched. Check both front and rear shoot bolts engaged.
 7. Harness tight.
 8. Temps and pressures within limits (engine).
 9. Controls full and free.
- Important:** Check that full rudder can be achieved before the rudder pedals contact the firewall. Cables stretch in service and anything less than full movement of the rudder **must** be remedied before flight.
10. Flight instruments set altimeter etc.; radio, G.P.S. and transponder tuned (if fitted).



11. Look out.

Passenger safety brief

It is good practice always to brief passengers on all flight safety aspects.

At Europa our brief consists of:

- ✘ Entry and exit of aircraft from trailing edge of main wing, *never forward towards the propeller.*
- ✘ Door latch operation - not to be opened in flight.
- ✘ Seat belt adjustment and operation.
- ✘ Position of fire extinguisher, fire axe and first aid kit.
- ✘ In case of emergency - keep quiet and follow instructions.

Taxiing

The tri-gear Europa is fitted with differential brakes and is an easy aircraft to taxi.

In all but strong winds the Europa should be taxied with the control stick held in the aft stick position.

In strong tail winds, 20kts +, the control stick should be in the neutral position.



Take off

The normal take off procedure is:-

Open throttle smoothly and keep the aircraft tracking straight, initially with differential braking then, once rudder authority has been achieved, with rudder pedals (be prepared to apply right rudder to counter blade effect).

The take-off run should be commenced with the stick slightly aft of neutral to reduce the load on the nose wheel. Once elevator control has been achieved, which will be at about 30 - 35 Kts, the nose can be raised slightly followed by a positive rotation at 50 Kts.

Climb initially at 55 kts to clear any obstacles, allowing the aircraft to accelerate to 60 kts before retracting the flaps. Retract the flaps in stages of about 5° or 6°.

Note: *With the Warp Drive propeller fitted you may find that the engine RPM in the climb will be slightly less than the static RPM. This is due to the propeller becoming more effective as the aircraft accelerates during the take-off run.*

Once the flaps have been retracted allow the aircraft to accelerate to 70 — 80 kts for the climb.

A cruise climb of 90 — 100 kts may be preferred as this will give better engine cooling and greater field of view over the nose of the aircraft.

Climb checks

1. Flaps up
2. Engine temperatures and pressures within limits.



3. Fuel pump - above 1000 ft
above ground level

(912) off

(914) secondary pump off

Short or rough field take off

(Refer also to performance section)

Set flaps to full down. Hold the aircraft on the brakes whilst applying full power. Release the brakes and apply sufficient rearwards pressure on the control stick to raise the nose as soon as possible. It will be possible to rotate and lift off at a lower speed than normal. The initial climb rate will be slightly less than normal.

Important: *Do not try to fly the aircraft off the ground before flying speed has been reached. On a rough field where the aircraft is being thrown into the air by undulating ground, resist the temptation to over rotate. This will simply stall the main wing, create increased drag and slow down or even stop the acceleration. By trying to force the aircraft off the ground too early the take off distance can easily be doubled and in the worst case extended indefinitely.*

High density altitude take off

Since every aircraft is different, accurate high density altitude take off distances are difficult to predict. Many factors affect take off performance such as gross weight, temperature, type and pitch setting of propeller, altitude, engine horsepower, pilot ability etc..

We recommend that each pilot determine high density altitude take off and landing performance for his own aircraft.



Europa Aircraft Co

In the acceleration and take off phase of flight, power available is the major consideration. By having an engine producing only 80hp to start with (Rotax 912) any loss in available horsepower through increased density altitude will have a greater effect than on an aircraft with say 160 hp.

As an example imagine two aircraft that require 60 hp to fly straight and level at 70 kts. Aircraft A has an 80 hp engine and aircraft B has 160 hp engine. Aircraft A has a surplus power of 20 hp available for climb whilst aircraft B has 90 hp. The higher the density altitude the lower the power available for climb. If in our example, the higher density altitude reduces the power available by 25%, aircraft A now has only 60 hp available and so would be unable to climb, Aircraft B still has $(120 - 60) = 60$ hp available for climb.

There is one other important point that needs considering and that is the use of flaps for high density altitude take offs.

For an aircraft to fly and climb, lift must exceed weight. This lift is created by the wings, but how *efficiently* this lift is generated is of major significance when considering high density altitude operation. Any increase in lift generates an increase in drag.

Wing flaps increase lift but at a price. That price is a disproportionate increase in drag that must be paid for by thrust and therefore engine power. The problem is that as flaps are deployed a greater price in drag has to be paid for the extra lift generated. In other words flaps produce extra lift but not as efficiently as a clean wing.

Referring to the earlier example, if it takes more power to generate the lift then the extra power available for climb will be reduced and even this power available for climb will not be used efficiently.



The best rate of climb for an aircraft is always when it is in the clean configuration.

The Europa is most affected by density altitude by:-

- ✧ being low powered (unless the 914 Turbo version of the engine is fitted).
- ✧ having flaps deployed.

A technique that can be used with the Europa to maximize high density altitude take off performance is to accelerate after lift off, at approximately 20 — 30 feet, to 55 kts and then in level flight carefully retract the flaps a few degrees at a time. Care must be taken not to let the aircraft sink back down onto the runway. The flaps should be completely retracted as 65 kts is reached. Once clean accelerate to 75 kts before climbing.

Important: *This technique should only be used when it has been practiced at safe heights of 500 ft plus.*

Pilots who fly regularly at high density altitudes know what to expect in terms of reduced aircraft performance and are prepared for it.

For those who are not and end up being thrown in at the deep end, the first thing that you may become aware of is that the aircraft appears slow to accelerate and, once airborne appears to want neither to climb nor to accelerate. You may be alarmed, thinking that the engine has lost power and in a way, of course, it has.

The **worst** thing that the pilot can do at this stage is to try to make the aircraft climb by pulling back on the stick and reducing airspeed further.



Europa Aircraft Co

Note: *A reduction in take off and climb performance can be quite marked even at a density altitude of 3000 feet so don't think that you have to be up in the Alps or the Rockies for it to catch you out.*

Cross wind take off

The Europa has quite a small, round, rear fuselage, a fairly small fin, and a powerful rudder.

The demonstrated cross wind component of the aircraft is 15 kts. With the Rotax engine fitted, which turns the propeller clockwise as viewed from the cockpit, the effect of engine torque, the rotating prop wash and gyroscopic precession of the propeller makes a cross-wind from the port side the worst case. If the wind is at 90° to the runway, take off with the wind from the right.

Be prepared to use substantial differential braking to keep the aircraft straight in the early part of the take-off run.

Practice your cross wind take offs and landings on a wide runway and *gradually* build up your experience.

Europas have been operated in cross winds greater than 20 kts but pilot skill and experience is very important. Find the cross wind limit that *you* are comfortable with and *stick to it*.

Remember: *The superior pilot uses his superior judgement so that he never has to demonstrate his superior skill!!*

Cruise

Manoeuvring speed is 97 KIAS, remain below this speed in rough air.



Depending on aircraft weight and propeller setting 5,000 — 5,200 rpm with the Rotax 912 engine should result in a 120 kts IAS cruise and a fuel burn of approximately 4 imperial gallons per hour (18 — 20 litres per hour) or in motor car terms 35 m.p.g.

A typical economy cruise would be 100 kts IAS resulting in a fuel burn of approximately 2½ imperial gallons per hour (11 — 12 litres per hour) or 46 m.p.g.

75% power at 8,000 ft should give a true airspeed of 130 Kts. Unfortunately the Rotax 912 engine is not equipped with mixture control nor are the carburettors altitude compensating so the gain in fuel economy with altitude is not as great as it could be.

There are many features designed into the Europa to make it comfortable in the cruise. The rudder pedals are designed so that the pilot or passengers can tilt their feet inwards and relax them in a stretched out position in front of the rudder pedals. This places more of your weight on the thigh support rather than the spine, and greatly increases comfort on long flights.

The instrument module has a moulded tray area which is level in the cruise. This can be used for drinks and refreshments.

The silencer system and draught proof door seals give a quiet cruise with low noise fatigue.

Regularly check engine temperatures and pressures and fuel remaining whilst in the cruise.

Descent

The Europa has low drag so plan your descent early. Arriving overhead your desired airfield at 6,000 feet is a waste of time and fuel.



Europa Aircraft Co

Although the Rotax water cooled engine is less susceptible to shock cooling than its air-cooled cousins it is still good practice to keep some power on in the descent.

As a rule of thumb use 3 miles per 1,000 feet to plan your descent.

Airfield approach checks

F – Fuel	sufficient
R – Radio	tuned
E – Engine Temperatures and Pressures	within limits
D – Direction Indicator	synchronized with compass
A – Airframe	surplus equipment stowed

Approach and landing

Circuit or pattern speeds are best flown at 90 - 100 kts. Flap limit speed is 83 kts.

Flapless approach and landing

In the event of flap motor failure a flapless landing will be necessary. At the normal approach speed of 60 Kts the nose attitude will be too high to give adequate forward vision, therefore the approach should be made at 70 Kts. The approach should be flown flatter than normal otherwise speed control will be difficult. Expect slower deceleration in the flare so aim to reduce power to idle before crossing the threshold so that the airspeed has diminished to about 60 Kts. As the nose is raised in the flare, you will have to rely more on peripheral vision to assess height.



Tie down Parking Control locks

The Europa is best tied down at the main and nose wheels. Controls can be secured by placing the seat belt around the control column and tightening them. The rudder will require a separate lock in gusty conditions.

Stalls

Note: *Some form of stall warning device, providing between 5 and 10 Kts of pre-stall warning, is mandatory on the Europa. Stall strips which induce the wing roots to stall first, located on the leading edges of both wing roots, are suitable and enable poor stalling behaviour to be tuned out (refer to Flight Testing for correct fitting procedure). Without stall strips the stall will be less predictable and provide less airframe buffet pre-stall warning.*

Warning: *Intentional spins are prohibited in the Europa. We recommend that stalls are practiced with recovery by 3,000 ft A.G.L.. Be familiar with standard spin recovery techniques before practicing stalls.*

An aircraft can stall at any airspeed and attitude but the recovery is always the same - stick forward to break the stall.

Just prior to the stall a slight to moderate airframe buffet may be felt. If the stick is moved full aft a more pronounced buffet will be felt accompanied by a pitch oscillation before the nose drops. To recover, ease the stick forward and counter any wing drop with rudder.

Although the ailerons remain effective up to and during the stall, any wing drop should not be contained by use of aileron but by using rudder to prevent further yaw and therefore further wing drop. Recover the stall in a wing down attitude, then once flying speed is re-established, level the wings and pull out of the dive.



Power off stalls

When practicing power off stalls remember to first carry out HASELL safety checks.

- | | |
|---------------------|---|
| H – Height | recovery by 3,000 ft A.G.L.. |
| A – Airframe | flaps as required. |
| S – Security | no loose objects, harness secure. |
| E – Engine | Temperatures and Pressures within limits, fuel sufficient. |
| L – Location | clear of built up areas, airfields, controlled airspace, cloud. |
| L – Look out | check for other aircraft. |

Progressively bring the stick back to prevent a descent and, as the aircraft stalls, ease the stick centrally forward and simultaneously apply full power to recover then level the wings and ease out of the dive. Practice these stalls both in the clean and landing configuration. Take care not to exceed 83 kts in the recovery with the flaps down.

Power on stalls

Practice these stalls with increasing amounts of power, bringing the stick progressively back until the stall occurs - with higher power settings right rudder will be required to keep the aircraft in balance (with clockwise rotation of the propeller as viewed from the cockpit). As power is increased there is more likelihood of a wing drop during the stall.



Europa Aircraft Co

Recovery is always the same; ailerons neutral, stick forward, countering any wing drop with rudder.

Warning: *Power on stalls can more easily lead to a spin entry. Give yourself plenty of recovery height. The Europa is a very clean aircraft and will pick up speed very quickly in a dive. Power is not usually necessary to aid in the recovery from a stall unless you don't want to lose altitude, as on the approach to landing.*

Spinning

Intentional spinning is prohibited.

Both the proof-of-concept (P.O.C.) aircraft G-YURO and the kit prototype G-ELSA have been extensively spin tested, up to 12 turns, and found to have excellent spin recovery with standard spin recovery techniques. Both aircraft were also found to recover satisfactorily from fully developed spins by removing both hands and feet from the controls depending on trim setting.

However, due to builder differences, individual kit aircraft may not exhibit the same spin characteristics as our prototypes. The prototype aircraft have a developed spin rate (after 3 turns) of approximately 180° per second with a 60° nose down attitude.

If a spin is inadvertently entered;

- ✘ Close the throttle.
- ✘ Retract flaps if deployed.
- ✘ Full rudder against direction of spin.



- ✘ Slight pause.
- ✘ Stick forward to neutral.
- ✘ Centralise rudder as spin stops.
- ✘ Recover from dive to a climbing attitude, applying power as the nose passes above the horizon.



Europa Aircraft Co

INTENTIONALLY BLANK



SECTION 6

Weight and Balance

To operate the Europa aircraft safely it must be flown within the prescribed weight and centre of gravity limits. Flight outside these limits is dangerous and could lead to loss of control.

Maximum gross weight 1370lb (621 kg).

Flight C of G limits:

- ✧ Forward 58.0" aft of datum
- ✧ Aft 62.5" aft of datum

These limits are equal to 17% – 26% mean aerodynamic chord (MAC).

The datum is a point 29.25" forward of the rear edge of the cowling joggle in the fuselage moulding.

Empty weight and C of G calculations

Before any flight is made an accurate weight and balance check needs to be carried out on your completed aircraft.

Use the aircraft prepared for service (APS) weight. The APS weight of your aircraft will be the basic weight of the aircraft complete with engine oil and *unusable* fuel plus all equipment that will remain on board the aircraft - e.g. fire extinguisher, first aid kit.

Important: *The aircraft must be weighed in the level attitude.*



Equipment required to carry out C of G measurements

- ✘ Two accurate weighing scales, one of which must be able to read up to approximately 750lb/350kg. (Note -bathroom scales have insufficient accuracy).
- ✘ Plumb bob.
- ✘ Tape measure.
- ✘ Spirit Level.
- ✘ Chalk or pencil to mark floor.
- ✘ Pen and paper.
- ✘ Two people.
- ✘ Calculator.
- ✘ One brain (switched on).

1. Level the aircraft on smooth, level ground by placing the spirit level on the port side door rebate placing foam blocks or similar under the appropriate wheels.

2. Hang a plumb bob from the rear edge of the cowling/fuselage joggle on the port side down to the floor and mark the position; repeat on the starboard side. Join the two marks together and find the centre. Construct a line at right angles going forward from the centre of the first line, and mark off a distance of 29.25" (74.3 cm). This point is the datum and is Fuselage Station Zero(FS 0.0). See figure 1.

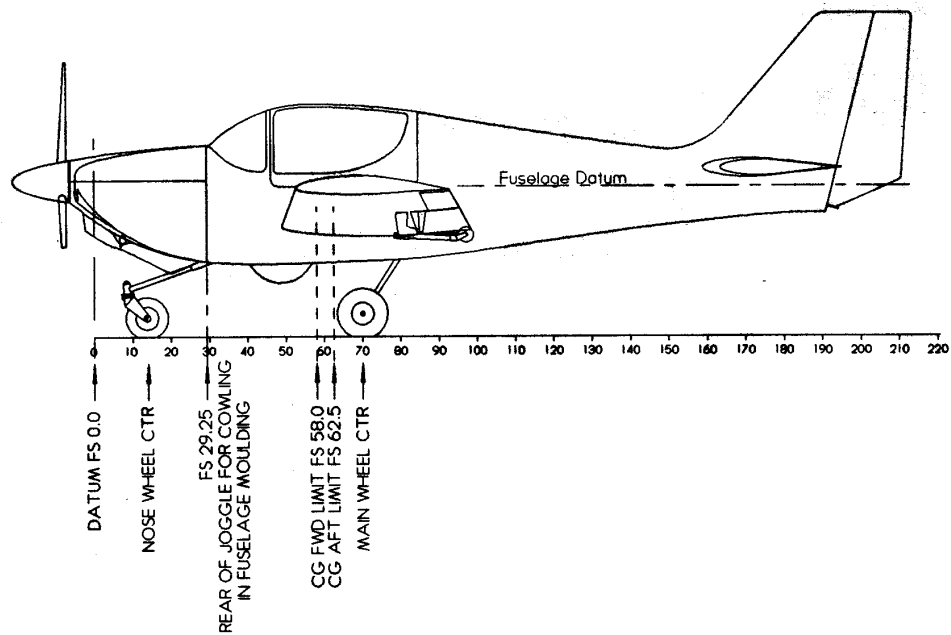

Fig 1.

3. Carry out a similar operation to find the positions of the main wheels and the nose wheel.

The main wheels should be at approximately FS 70, that is 70" aft of the FS 0.0 mark. Similarly, the nose wheel should be close to FS 15.

Once you have accurately recorded the positions of the main wheels and nosewheel, weigh the aircraft in this level attitude. Start a record similar to the one below for *your* aircraft.

NOTE: *Make sure that you subtract the weight of any blocks or chocks placed on the scales to steady or support the aircraft.*

The fuselage stations of the main and tail wheel or “arm” is in inches in our calculations and the weight is in pounds (lb.), however you may convert the arm and weights to metric if so desired.



Now for the calculations

The formula is : $WEIGHT \times ARM = MOMENT$.

Aircraft registration G-ABCD. Weighed on 1 August 1998, by A.N. Other.

A.P.S. Weight includes- engine oil, unusable fuel, fire extinguisher, first aid kit, fire axe, seat cushions.

Item	Weight (lb)	Arm (inches)	Moment
Port main wheel	315	70.25	22128.75
Stbd main wheel	318	70.25	22339.50
Nose wheel	155	14.75	2286.25
A.P.S.	788	59.3	47049.50

Complete your table, calculating the moment for the main wheels and nose wheel.

Now add together the moments to give a total moment.

Similarly add together the weights to give your total or A.P.S. weight.

Divide the total moment by the total weight and this will give you the arm or C of G position for your A.P.S. weight.

TOTAL MOMENT

TOTAL WEIGHT = A.P.S. C of G.



Once you have completed the A.P.S. C of G calculations (which will require re-doing if equipment is added later or removed from the aircraft) you can proceed by adding pilot, passenger, baggage and fuel weights to calculate the flight C of G.

The arm for the pilot and passenger is 56".

The fuel arm = 76".

The baggage arm = 88".

Note: *Fuel = 7.2lb per imperial gallon*

Carry out calculations with various aircraft loadings until you fully understand the limits applicable to your aircraft. For example; due to differences in build, which may affect the A.P.S. weight and C of G, it could mean that your baggage capacity is restricted when, for instance, carrying two 180lb adults and full fuel.

Note: *Both zero fuel C.G. and take off C.G. should be within the C.G. limits bearing in mind that all weight limitations are adhered to.*

Item	Weight (lb)	Arm (inches)	Moment
A.P.S.	788	59.3	47049.5
Pilot	180	56	10080.0
Passenger	160	56	8960.0
Baggage	50	88	4400.0
Zero fuel weight	1178	C. of G. 59.83	70489.5
Fuel	110	76	8360.0
Take off weight	1288	C. Of G. 61.22	78849.5



Refer to the loading diagram and plot the total weight and the C of G position. Make sure that you stay within the weight and C of G limits.

Note: For the first flight the total weight and C of G should be within the First flight box shown on the graph.

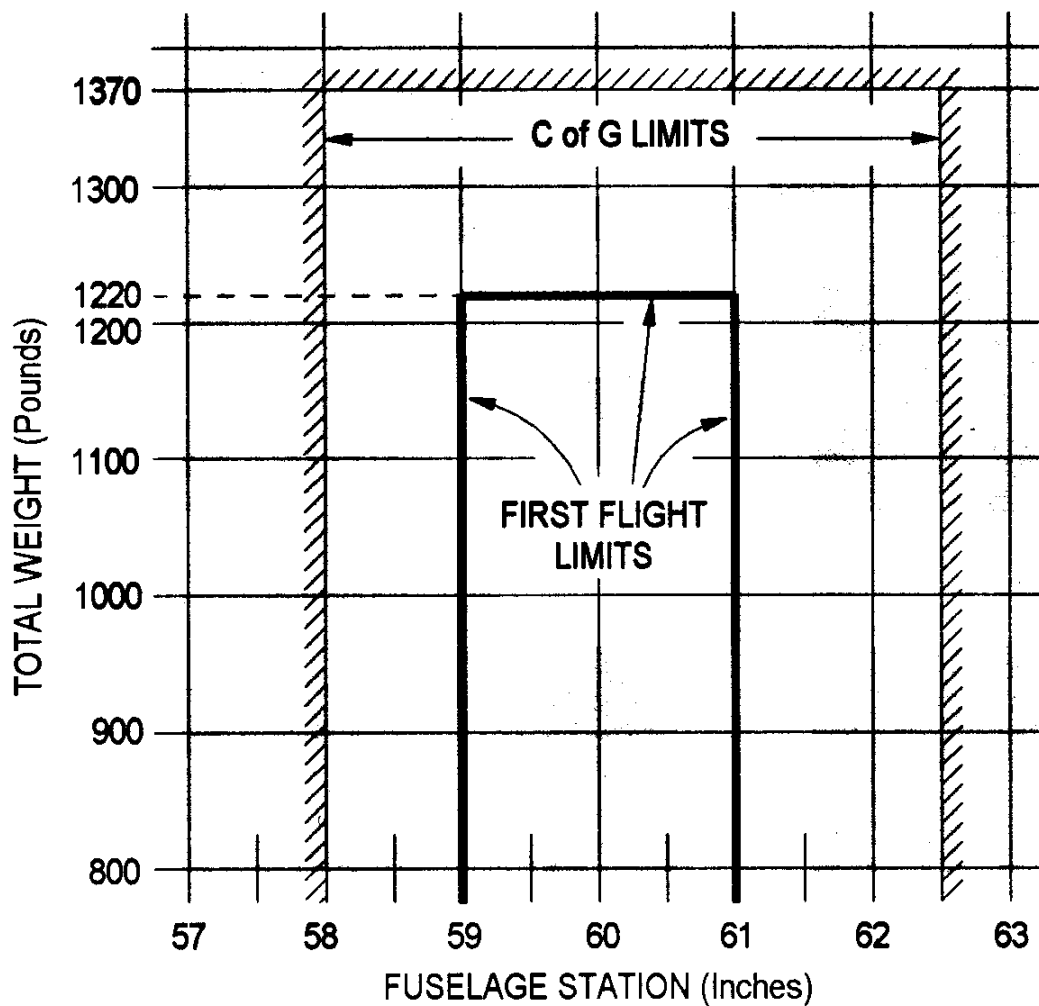



Glossary of terms

Datum

An imaginary vertical plane from which all horizontal distances are measured for balance purposes.

Station

A location along the aircraft fuselage usually given in terms of distance from the reference datum.

Arm

The horizontal distance from the reference datum to the centre of gravity (cg) of an item.

Moment

The product of the weight of an item multiplied by its arm.

MAC (Mean Aerodynamic chord)

Is the wing area divided by the span.

Aeroplane centre of gravity

The point at which an aeroplane would balance if suspended. Its distance from the reference datum is found by dividing the total moment by the total weight of the aeroplane.

C.G. Arm

The arm obtained by adding the individual moments taken at the aircraft and dividing the sum by the total weight.

C.G. Limits

The extreme centre of gravity locations within which the aircraft must be operated at a given weight.



Europa Aircraft Co

A.P.S. Weight

Weight of an *aircraft prepared for service*, which includes *unusable* fuel, engine oil and fluids and optional equipment.

Maximum gross weight

Maximum gross weight approved for flight operations.

Maximum useful load

Difference between maximum gross weight and A.P.S. weight.

Useful load

Weight of occupants, baggage and fuel.

Zero fuel weight

Weight of aircraft without useable fuel.



Fill in the appropriate blank spaces and photocopy this page to keep with the aircraft.

	Weight (lb)	Arm (inches)	Moment
A.P.S.		C. of G.	
Pilot		56	
Passenger		56	
Baggage		88	
ZERO FUEL WEIGHT		C. of G.	
Fuel		76	
TAKE OFF WEIGHT		C. of G.	

	Weight (lb)	Arm (inches)	Moment
A.P.S.		C. of G.	
Pilot		56	
Passenger		56	
Baggage		88	
ZERO FUEL WEIGHT		C. of G.	
Fuel		76	
TAKE OFF WEIGHT		C. of G.	

Note: You will need to carry out a new APS C of G check if the aircraft is repainted or has equipment removed or added.



Europa Aircraft Co

INTENTIONALLY BLANK



SECTION 7

Initial systems check

Before any taxi or flight testing can commence each newly completed aircraft requires a very thorough inspection and systems check-out.

Your first flight is not the time to start wondering whether a particular part of the control system was tightened.

When carrying out any inspection work on an aircraft always work methodically to a check list making notes of any work required. Discipline yourself to work methodically. Make a list - engine mounting, exhaust, wiring, oil system, cooling system, induction system, engine controls, propeller and spinner, etc. and then methodically inspect *every* part of that particular system *before* moving onto the next.

Never be afraid to ask other, perhaps more knowledgeable, people for advice.

Independent final inspections by two people is strongly recommended and is a mandatory requirement in many countries.

Eventually you will arrive at a situation when you have simply run out of excuses not to fly!

But first.....complete a weight and balance schedule as described in Section 6.



Fuel system

Verify that your fuel selector valve is working in the correct sense and clearly placard **OFF - MAIN** and **RESERVE**.

With the aircraft in the level attitude carefully fill the fuel tank, checking regularly for fuel leaks, and calibrate your fuel gauge at the same time.

Due to the differing expansion rates of the polyethylene all the fuel tanks will be slightly different so make a note of *your* maximum capacity. Once your tank is full, inspect the entire fuel system for security and leaks.

Engine

Before using the starter motor for the first time ensure that the oil system is properly primed according to the Rotax Operators Manual - *failure to do this could result in engine seizure*.

Check that the ignitions are not “live” when in the off position. The Rotax engines have a magneto ignition system which needs to be grounded back to the engine to be “dead”.

Check all engine controls and instruments for correct operation. If in doubt cylinder head and oil temperature gauges can be checked by immersion of the sender units into hot oil and calibrated by using a high temperature candy or cooking thermometer.

Before first flight you will need to have run the engine for a minimum total of two hours without any problems. This will test also the engine support systems.



After each engine run check:-

- * Fuel system for leaks and chafing hoses.
- * Throttle and choke cables for correct operation. Check that application of full throttle actually activates both carburettors simultaneously.
- * Water system for leaks, tightness of securing clips, chafing of pipes.
- * Radiator for security and chafing.
- * Oil system for leaks and chafing hoses.
- * Exhaust system for security, leaks and cracking.
- * Propeller
Install and check according to the manufacturers instructions. Check pitch is as recommended in the Rotax 912 or 914 Engine Installation Manual

Torque and safety wire propeller bolts.
- * Spinner for true running, cracks and security.
- * Idle check set idle to be 1400 - 1600 r.p.m.
- * Static rpm approximately 5100 rpm.



Fuel flow check

You will need to know that your fuel system can supply sufficient fuel to the carburettors to sustain maximum power. Both the mechanical (912) and electric fuel pumps must be checked independently. See Engine Installation Manual for details.

Airframe

Check:

- ✧ Main gear leg attachment secure, brake attachment bolts and axle bolts secure, bearings packed with grease.
- ✧ Nose gear leg condition, shimmy damper operation, bearings correctly grease packed.
- ✧ Tyre pressure for correct inflation - 30 psi (2.0 bar). Leave for 24 hours then check again.
- ✧ Brake system for correct operation, brake pad wear, leaks and chafing of hydraulic pipe. Bleed by pumping fluid up from the bleed nipples to the master cylinders.

Paint creep marks onto the main wheels and tyres.

Check the entire flap operating mechanism for adjustment, correct operation, security of all nuts, bolts, pins and fittings.

Bungee cord

The bungee cord is there to act as a safety overload protection in case of overload of the nose gear, to prevent bending of the nose gear leg. It is not intended that the pre-tension will be exceeded normal operation.



Flying controls

Check the ailerons for smooth operation and that they fair into the trailing edge at neutral.

Aileron travel should be:

- * trailing edge down $20^{\circ} +2^{\circ}/ -1^{\circ}$
- * trailing edge up $23.5^{\circ} +2^{\circ}/ -1^{\circ}$

Check the entire control system against the builders manuals for the correct installation of all parts paying particular attention to the correct bolt lengths, orientation, washers, lock nuts, castle nuts and pins. Check all rod end bearings for correct installation and check nut security.

Check all control system attachment points (anti-servo/trim tabs, ailerons, rudder and flaps) for correct attachment, security and operation. Check hinge alignment and freedom from binding.

Check the tailplanes for full and free movement and security. Check the anti-servo trim tabs for correct operation and freedom of movement.

Tailplane movement should be:

- * trailing edge down $4^{\circ} +1^{\circ}/ -0^{\circ}$
- * trailing edge up $12^{\circ} +1^{\circ}/ -0^{\circ}$

With the tailplanes in the neutral position set the anti-servo/trim tab with the trim switch so that its trailing edge lines up with the tailplane trailing edge and confirm that the pitch trim indicator needle also indicates neutral.



Europa Aircraft Co

With the tailplanes and tabs set to zero, place your inclinometer on the flat aft portion of the tailplanes outboard of the trim tab and make a note of the reading.

The tailplane *trailing edge* needs to rotate 12° upwards and 4° downwards to cover the full range required.

You will notice (I hope) that as the trailing edge of the tailplane is raised the trailing edge of the tab raises even further, the ratio is approximately 1.3 to 1. Therefore, when you have raised the trailing edge of the tailplane by 12° the tab should have raised 15.6° relative to the tailplane or 27.6° from the zero start position. A tolerance of $+2.4^\circ$ and -1.2° of tab movement is acceptable.

Similarly, moving the tailplane trailing edge down 4° from the zero reference point the tab should move down approximately 5.2° relative to the tailplane of 9.2° the zero reference position. A tolerance of $+0.8^\circ$ and -0.4° of tab movement is acceptable.

Pitch trim control

Check that when pressing the bottom of the pitch trim rocker switch for nose up trim the indicator needle moves up and the anti-servo/trim tab moves trailing edge down. With the tailplanes held in the neutral position operate the trim motor to confirm that the anti-servo/trim tab will move up and down at least 6° .

Flettner strips

Flettner strips are fitted to the trailing edge of the tailplane tabs to assist in damping out the short period oscillations in pitch.



A brief explanation

The Europa is fitted with a powerful all flying tailplane which is pivoted close to its centre of lift. Having a tailplane alone would result in there being little feed-back to the pilot, no matter how much work it was doing. The pilot needs to feel a resistance, or stick force, relative to the work being done by the tailplanes and this stick force should increase with an increase in “g”.

To provide this stick force a tab is fitted to the trailing edge of the tailplane which is geared so that it opposes its movement (an anti-servo tab).

When the pilot pulls back on the control stick the trailing edge of the tailplane moves upwards. The trailing edge of the tab also moves upwards, therefore resisting the movement of the tailplane. The tabs attempt to maintain the “status quo”. It is the force generated by the tab that the pilot feels.

In the “stick free” situation, where the pilot has released the control stick, the tab controls what happens to the tailplane. Firstly, the tab can be moved independently of the tailplane to act as a pitch trim control. Secondly, if the tailplane is upset by a sudden gust it is the tab that drives the tailplane back to its original angle of attack.

Because the tab is attached to the trailing edge of the tailplane it has a tendency to float slightly within the turbulent boundary layer of air. This makes the tab less effective at damping out any oscillations of the tailplane.

To give the tab an immediate bite into the airstream the trailing edge of the tab is thickened slightly. These areas of extra thickness are called Flettner strips.



Europa Aircraft Co

Without these strips fitted to the Europa we found the aircraft wandered slightly in pitch and had a different qualitative feel which led some pilots to over control in pitch and get into a P.I.O. (pilot induced oscillation) situation.

Fitting of Flettner strips to the tailplane tabs is *mandatory*, and is covered in the Builders Manual.

IMPORTANT: *Check tailplane balance after fitting Flettner strips.*

With the aircraft level, set the tailplane to its neutral position. If it moves from this position once you let go of it then clearly it is out of balance and will require adjusting accordingly.

Once you get to the fine tuning stage we found that the best way to do this was to simply rotate the tailplane gently each way in a rocking motion by pushing down on the upper surface forward and aft of the pivot point, checking for the same force being required to reverse the direction once the balance is correct.

Firmly secure *all balance weights* to the balance arm then double check the tailplane for full and free movement.

Check the rudder system for correct operation.

Check the cables for security and chafing, pulleys for freedom of movement and cable security under the pulleys.

Note: The cables will take a "set" or lengthen slightly in service. You can either sit in the cockpit and apply a foot force of approximately 25kg (55lb) onto each pedal for 24 hours or rig up a wedge of some kind possibly off the seat front to do the same job.



Make sure that after this initial set that full rudder movement can be achieved before the rudder pedal or your foot contacts the firewall; conduct this test by having someone apply an opposing force of approximately 20lb at the rudder to simulate air loads.

Rudder movement should be:

30° +2°/ -0° each way.

None of the company's Europas have ever experienced any flutter of the control surfaces but this does not guarantee that slight builder inaccuracies will not act as a trigger for flutter on other Europas.

Check all wing attach pins for cracking or corrosion; wing spar and fuselage bushes for wear, corrosion or looseness.

Check doors, seals, hinges and latches for correct operation and security of door closure.

Note: *The non-tapered parts of the door shoot-bolts should enter into the holes in the fuselage.*

Check seat belts for correct installation, security and adjustment.

Swing the aircraft compass and fill in a correction card.

Brakes and steering testing

To check for leaks and to avoid overheating, leave off the wheel fairings.

Ensure, before you start the engine, that the parking brake is set to 'on' and the brake levers have been pulled to pressurise the system.



Europa Aircraft Co

You should have plenty of room ahead and either side of the aircraft, as a single brake malfunction could result in the aircraft turning as it moves forward.

Having primed yourself that things may not go as expected, start the engine, then when ready release the brakes. Check that both brakes work and that approximately the same force is required on each lever.

Next check that it is possible to turn the aircraft by using each brake in turn. The best technique is to pull and release the appropriate lever as many times as required, rather than hold it on, which could cause the aircraft to slow down too much. If you have difficulty turning the aircraft, but the brakes are working properly, check the nose-wheel shimmy damper friction adjustment.



SECTION 8

Service and Maintenance

Composite structures

The Europa should be painted white to minimise the structural temperature in hot, direct sunlight conditions and also to minimise the thermal stress across a structure e.g. the top and bottom surfaces of the wings or tailplanes.

Do not expose unprotected glass fibre or foam to sunlight for extended periods. Unpainted areas should be re-touched and the paint system used should contain a pigment to give high U.V. protection.

The high surface durability and safety margins designed into the Europa make it highly resistant to damage or fatigue. If the structure is damaged it will show up as a crack in the paint or wrinkle in the skin. Remove the paint around the crack by sanding and inspect the glass structures. Do not use any lacquer or paint remover on your Europa. If the glass structure is damaged it will have a white appearance indicating either torn (tension) or crushed (compression) fibres. If there is no glass damage it will be smooth and transparent when sanded.

Plexiglas screens

Due to the uniform bonding and lack of metal fasteners your Europa screens are less susceptible to cracking than most other aircraft. If a crack up to 3" long does occur, drill a 1/8" hole through the Plexiglas at the end of the crack to prevent it growing further. Cracks longer than 3" require the screen to be replaced.

Engine, propeller, batteries and accessories; follow manufacturers recommendations for maintenance/inspection.



Europa Aircraft Co

Every 25 hours for the first 100 hours then every ***50 hours***.

- * Clean spark plugs, re-gap as necessary, change every 100 hours.
- * Inspect ignition harness.
- * Change engine oil and filter (see Engine Manual).
- * Check exhaust system for leaks, cracks and security.
- * Battery inspection:-
 - ✧ Clean terminals.
 - ✧ Clean battery box.
 - ✧ Check electrolyte level and top up if required.
 - ✧ Inspect drain tube and vent lines for obstruction and correct routing.
- * Inspect all electrical wiring for security and chafing.
- * Clean induction air filters.
- * Check coolant level, all hoses for chafing, cracking and leaks.
- * Check radiator and oil cooler for security, damage, leaks and blockages of fins.
- * Check oil lines and cooler for leaks, security and damage.



- * Change/clean in-line fuel filters, check all lines for chafing security and leaks.
- * Engine mount and main landing gear mount for cracks/damage.
- * Spinner for cracks, tracking and security.
- * Check cowlings for chafing and security.
- * Start engine and warm up thoroughly

Engine run up

- * Take note of:-
 - ✘ Oil pressure
 - ✘ Voltage output
 - ✘ Left ignition RPM drop
 - ✘ Right ignition RPM drop
 - ✘ Suction gauge (if fitted)
 - ✘ Static max RPM
 - ✘ Idle RPM
 - ✘ Ignition cut off (ground)
- * Clean engine and inside of cowls with a suitable cleaner/degreasing agent.



Controls

Remove wings and tailplanes.

Wings

- * Inspect:-
- * Wing connect pins for cracking and re-grease.
- * Main spar and bushes for wear and security.
- * Aileron quick-connect mechanism for smooth operation, cracking.
- * Remove inspection cover and inspect aileron bellcrank and rod ends for security and smooth operation.
- * Aileron and attachment for security, cracking, hinge wear, smooth operation. No chafing or binding.
- * Flaps for correct operation, cracking, hinges in both wing and flap. Security of flap drive pin.
- * Pitot/static for blockage, kinked tubes, damaged connectors.

Fuselage

Inspect:-

- * Control system through spar hole for correct operation, damage, chafing, cleanliness, corrosion.
- * Fuel tank outlets for security and leaks.



- * Wing attachment lift pin bushes in seat back. Check for damage, looseness and corrosion.
- * Wing sockets on fuselage sides - check for security, cracking, corrosion. Inspect surrounding structures for cracking and damage.
- * Pip pin for correct fit and security on rear fitting. Check also pin freely springs to locked position
- * Pitch and roll control systems for correct operation, security of all rod ends, etc.
- * Tailplane mass balance weight and control stops for damage and security.
- * Nose wheel assembly for correct operation, tyre wear, inflation, damage and cracking. Shimmy damper for correct setting.
- * Tailplane torque tube for security, cracking and corrosion both inside and outside. Regrease as necessary.
- * Electric pitch trim motor and mechanism for correct operation, corrosion and damage.
- * Flap drive motor for correct operation, security.
- * Tailplane drive pins for cracking. Lightly re-grease.
- * Doors for damage and safe operation.
- * Hinges for security and wear.



Europa Aircraft Co

- * Shoot-bolts and latching mechanism for damage and correct operation.
- * Rudder pedals for cracking and freedom of operation. Confirm that full rudder movement can be achieved before the rudder pedal contacts the firewall.
- * Brakes for wear, leaks, chafing and correct operation.

Important note: *The correct brake fluid must be used otherwise brake failure may result. Tri-gear aircraft with foot brakes use aviation type mineral based fluid and those with finger brakes use DOT 5 fluid.*

Tailplane and Anti-servo/trim tab

Check:

- * Skins for signs of cracking or buckling.
- * Tab hinges for binding and wear, Tab drive pin and bracket for corrosion, cracking.
- * Main tailplane bushes for security and cleanliness.
- * Tailplane drive bushes in inboard rib for wear and security.
- * Rudder for cracks and hinge wear.
- * All control surfaces for backlash, chafing and correct operation.

Note: *If new brake pads have been fitted, run them in according to the appropriate procedure described below. Brake pads supplied by Europa Aviation Ltd. have Metallic Linings.*



- * 1. Perform two (2) consecutive full stop braking applications from 30 to 35 knots. Do not allow the brake discs to cool substantially between the stops.
- * 2. Allow the brakes to cool for 10 to 15 minutes.
- * 3. Apply brakes and check for restraint at high static throttle. If brakes hold, conditioning is complete.
- * 4. If brakes cannot hold aircraft during static run-up, allow brakes to cool completely, and repeat steps 1 to 3.

These conditioning procedures will wear off any high spots and generate sufficient heat to create a thin layer of glazed material at the lining friction surface. Normal brake usage should generate enough heat to maintain the glaze throughout the life of the lining.

Properly conditioned linings will provide many hours of maintenance free service. A visual inspection of the brake disc will indicate the lining condition. A smooth surface, one without grooves, indicates the linings are properly glazed.

If the disc is rough (grooved), the linings must be reglazed. The conditioning procedure should be performed whenever the rough disc condition is observed.

Brake Disc: Inspection and Service

The Matco brake disc should give years of trouble-free service under normal field conditions.



Europa Aircraft Co

Conditions such as unimproved fields, standing water, industrial pollution, even infrequent use of the aircraft, may require more frequent inspection of the discs in order to prolong the life of the brake lining.

The disc faces should be checked for wear (minimum thickness 4.25 mm (0.167")), and for any grooves, deep scratches, excessive pitting, or coning of the brake disc. Coning beyond 0.4 mm (0.015") in either direction would be cause for replacement. Coning, however, is rarely a problem.

Isolated grooves up to 0.75mm (0.030") deep should not be cause for replacement, although general grooving of the disc will reduce the lining life.

Discs are normally plated for rust prevention, but the plating wears off where the lining rubs in just a few landings. The remaining portion of the disc should be corrosion free for several years under normal use.

Rust in varying degrees can occur. If a powdered rust appears, one or two taxi-braking applications should wipe the disc clear. Rust build-up beyond this point, may require removal of the disc from the wheel to properly clean both surfaces. Wire brushing followed by sanding with 220 grit sandpaper should restore the braking surfaces adequately.



Brake lining installation

Following are instructions on how to properly remove and replace brake linings on the brake shoes.

Remove the old brake lining by drilling from the crimped side of the rivet. Using a 3.8 mm drill (0.1495 diameter), drill through the rivet taking care to avoid damaging the rivet hole. After drilling crimped edge off all rivets, carefully lift old lining and remaining rivet pieces off of brake shoe. A punch should not be used to remove the rivet as it may result in distortion of the rivet hole.

Inspect the brake shoe for any bending or other damage which may have occurred in service. A shoe with more than 0.25 mm (0.010") bend should be replaced. Inspect to ensure rivet hole has not been damaged during removal.

Using a rivet squeezer or pneumatic press, replace lining using 4-6 brass rivets only. A punch and hammer should not be used to replace the lining as it may result in damage to the lining, incorrect seating of the rivet, or distortion of the rivet hole.



Brake lining wear limits

To eliminate the use of brake linings beyond design limitations and reduce probability of piston damage and brake fluid drainage, we are issuing a restatement of brake lining wear limits.

All RA66 and M66 series brake linings should be replaced when the thickness of remaining wear material reaches 0.100 IN (2.54 mm).

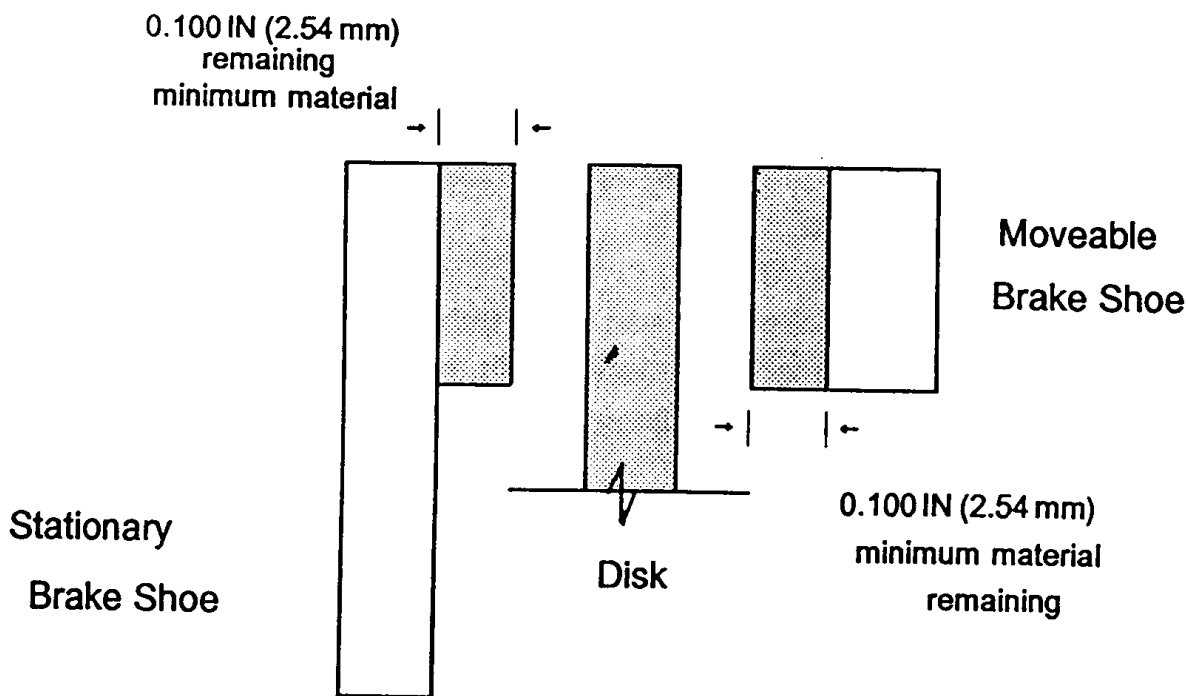

Heavy landing check

If you suspect that the landing gear may have been over stressed due to a heavy landing, the aircraft must be supported on chocks to bring the landing gear clear of the ground, and the gear inspected in detail. Check for security of the main landing gear mounting tubes, and the condition of the



main gear legs themselves. Check the nose gear leg and mounting frame - any deformation of the frame is unacceptable.

Annual check

Carry out all initial systems checks and items in the 50 hour check list except a weight and balance unless painting or modifications have been carried out that would affect the weight and balance of the aircraft.

Also:-

- * Check pitch angle on each propeller blade.
- * Remove and re-grease the nose and main wheel bearings (every 12 months).
- * Inspect entire airframe inside and out for signs of cracking or buckling.
- * Inspect all fuel lines for ageing and degradation. In any case it is recommended that all rubber items be replaced on a 5 yearly basis
- * Inspect all oil and water lines for ageing, cracking or degradation. This will usually show as a lack of suppleness in the pipes and possible surface cracking as pipes are flexed.
- * Inspect rubber carburettor mounting flanges for splitting (splitting will start from the inside).



Paper work

- * Make sure that all work carried out is recorded in the aircraft log books with any discrepancies and other pertinent information.
- * Check that any A.D. (airworthiness directives) issued against the aircraft, engine or other equipment have been carried out and duly recorded.
- * Check currency of certificate of airworthiness or Permit to Fly.
- * Check that Insurance is in force.
- * Review weight and balance schedule.
- * Placards in place.

Registration certificate available.

As you complete your Europa the day will arrive when every last job is finished and you have run out of excuses for not flying.

From here on things start to get more serious. The inanimate pieces of foam, epoxy, glass cloth, nuts, bolts and hardware that you have been working with over the months now want to take on a life of their own.

Whereas a mistake in your workshop could have cost you an Elastoplast on your finger and a little money to rectify the problem, mistakes from here forward could be far more costly. You have too much time, money and life invested in this project so make each step a sure and calculated one.

There are several things that you need to be aware of. One is a tendency to rush the last stages to get the aircraft flying, maybe you have set yourself a deadline or the promised attendance of a major air show could be colouring your judgment.

Two, is simply “ego”, I’ve built it so I will fly it. Who knows more about my aircraft than me? The builder is understandably proud of his creation and becomes very possessive.

The builder is quite likely to know more about his aircraft than anyone else but he may not have done as much flying as he would have liked to whilst building his aircraft and is therefore out of practice. *Flying currency* is the most important prerequisite for anyone contemplating carrying out the first flight of a new aircraft and is more important than total hours flown.

Before flying a Europa on first flight a pilot needs to be sharp and in current practice on a similar aircraft. It is better to have a pilot who has recently flown many different light aircraft than an airline pilot with 5,000 hours on 737's over the last ten years but nothing else.

Be honest with yourself, it may be much better to let someone with more experience conduct the first flight on your Europa.

Remember: *The **primary** reason for getting an experienced pilot to test fly an aircraft is not if everything goes ok but if something **goes wrong**. The experienced pilot is more capable of dealing with an emergency.*

For the experienced pilot the job of flying the Europa should be both straightforward and enjoyable.

Once airborne the Europa is entirely conventional in its handling. It has positive stick free stability and the controls are responsive without being twitchy. In short, it is a real "pilots" aeroplane.

Ground tests

Prior to taxi testing run the engine without the top cowl so that oil, coolant, fuel leaks and vibration problems can be spotted and remedied immediately.

Run the engine at various power settings from idle to full power.

Caution: *Make sure that the area is clear of objects and small stones and the aircraft is not facing towards or away from anything. Have a fire extinguisher close by outside the aircraft and know how to use it.*



Monitor the temperature gauges to avoid overheating the engine. Have someone, who is fully briefed to keep clear of the propeller, observe the engine and related systems from the outside whilst you control and monitor from inside the aircraft.

After each engine run check each system carefully - wiring, oil and water hoses for chafing and leaks. Use nylon ties to secure parts that are found to vibrate and chafe.

A full power engine check should be made before first flight. The engine should be uncowed and the full power run should be for a minimum of 2 minutes. Park the aircraft into wind for best cooling and close the engine down if excessive oil or cylinder head temperature are reached.

The reason for doing this is that after two minutes on its first flight the aircraft should be in a position 1,000 feet down wind to glide back to the field should it become necessary.

After the static engine tests have been completed and any defects remedied you are ready to commence taxi testing.

Taxi testing

Introduction

The most important rule for taxi testing is never to do them unless *you* and the *aircraft* are ready for flight.

It is quite a common occurrence to suddenly find that you are actually airborne and flying when you only had the intention of conducting a taxi test.



Europa Aircraft Co

The realisation that you are now on your first committed flight, the end of the runway having just disappeared under the nose, is not the time to note that you are not even strapped in your seat, the aircraft pitch trim was set full nose up now necessitating a healthy forward push on the stick, you have just half a gallon in the fuel tank, the passenger door latch is half open and the altimeter is showing 870 feet although you have only just cleared the boundary hedge. More importantly you were not mentally prepared for a first flight and the aircraft may not even have been loaded to bring it into the allowable C of G envelope.

To start make sure that when you sit in the cockpit you are comfortable and that your head is within 2.5 cm (1") of the top of the door. This is important to guarantee that you have the best field of view over the nose. Similarly you may need cushions behind you or the rudder pedals adjusting. Make sure that all the controls fall comfortably to hand or foot.

Take time to become familiar with all the controls so that you do not have to spend time hunting for them. Check the operation of all your flight controls, engine controls and instrumentation etc. Everything should operate smoothly with no binding or interference.

Make sure that the brakes are working properly before commencing taxi tests.

The purpose of the low speed taxi testing is to give the pilot a feel for the steering of the aircraft by use of the differential brakes. These initial tests should not exceed walking speed as the space needed to manoeuvre is explored.

The landing gear should be checked between taxi tests for defects - loose hardware, loose wheel bearings, brake wear, etc.



With the aircraft chocked, first check that the parking brake valve is in the 'OFF' position. When the braking system is fully purged of air, you should find that each brake lever moves aft a similar amount for a given effort. Any significant difference would indicate that air may still be present. The levers should also return to their fully forward position as you release them. Do not attempt to taxi the aircraft until the levers behave correctly as described above.

Set the parking brake to 'ON' and pull on both levers to pressurise the system. Remove any chocks and try to move the aircraft by hand, pulling on the lower part of the door surround. You should not be able to move the aircraft. Set the parking brake to 'OFF' and try to move the aircraft again. It should be free to move.

After all the above, go through the entire system, checking for leaks at any of the joints, and top up the reservoir as required.

High speed taxi testing

Warning: *Make sure that you and the aircraft are flight ready. High speed taxi testing should ideally be done in calm weather conditions, maximum wind 10 kts down the runway. The runway should be 800m (2,600 feet) minimum length and 30 m(100 ft) minimum width.*

As power is applied be prepared to apply a little right brake and rudder pressure to keep the nose tracking straight down the runway.

If the stick has been held well back, within the last two inches of movement, as the speed is increased the nose is likely to start lifting, and the aircraft starts to feel light on its main gear.

If the aircraft becomes airborne be prepared to move the stick forwards to decrease the angle of attack and increase the margin from the stall.



Europa Aircraft Co

Make sure that whilst taxiing that you can comfortably track the runway centre line. If you find that you are wandering off towards the runway side then you need more practice.

Be prepared to put in full aileron or rudder control as you transition through the high speed taxi to flight regime.

Try not to make jerky control inputs. The aeroplane will respond better and you are far less likely to get into trouble with smooth, steady, firm control inputs.

First flight

After completion of your taxi testing the aircraft will require a thorough inspection before first flight.

Check all the items in the initial systems checkout. Do this work carefully, take nothing for granted, remember the next step is the “big one”, the one you have been waiting for months or years to accomplish.

Important considerations

1. The pilot should be relaxed and confident, don't fly if you are feeling unwell for any reason, also don't fly if you are tired. It may be that taking care of a final glitch has taken all day to fix and you are wound up by the time it is ready to fly. In this situation it would be better to leave it until the following morning. Here at Europa we do all our first flights first thing in the morning when we are all bright eyed and bushy tailed.

We complete all our preparations the day before so that the only thing we have to do is get in and fly.



2. The weather should be calm and clear, any wind should be down the runway at 10 kts maximum.
3. Don't let a crowd gather and make you anxious and nervous. Have a friend or two present to help but don't make the mistake of letting everyone come. You will be calmer and more level headed.
4. Emergency procedures should be memorised and rehearsed mentally. The pilot should be familiar with open areas in the flight test area for use as possible emergency landing sites.
5. If you are at a controlled airfield, plan your first flight when they are least busy, early morning is usually best.
6. You should have at least 800m of runway for first flight with a clear climb out area.
7. Wear a parachute and practice getting out of the aircraft quickly.
8. Your first few flights should be with 20-25 litres (6-7 gallons) of fuel and secure ballast to bring the aircraft into the C of G first flight box at both take off and zero fuel weights.

The first flight is used to verify that the engine and primary control system are functioning normally and to begin to establish a feel of the controls and to note any necessary changes to control, rigging or trim.

Follow the normal operating procedures described in this manual.

Line up with the centre line of the runway. Smoothly and fully open the throttle being prepared to add right rudder to track the centre line (Rotax 912 and 914 engines).



Europa Aircraft Co

Concentrate on keeping straight with differential braking and rudder. If you do nothing else the aircraft will fly itself off the ground when it is ready. This will be at approximately 45 — 50 kts.

Be especially prepared to contain any out of trim forces in pitch.

Once airborne if there are any serious handling problems they should be evident immediately. If there are, close the throttle and land ahead within the remaining runway.

If all is well, allow the aircraft to accelerate to 55 — 60 kts before climbing. Once established in the climb, trim to maintain climb speed of 55 — 60 kts. Climb to 500 ft before raising the flaps, having established a speed of 60 — 65 kts. Raise the flaps in stages of a few degrees over a period of 4 — 5 seconds at least, easing the stick forward to contain the slight pitch up which occurs when raising the flaps. Once this has been carried out continue climb at 80 kts.

Make a gentle turn downwind and monitor engine temperatures. If excessive try reducing power and fly straight and level. If they continue to climb return to the airfield and resolve the problem.

Note: *Be alert to any peculiar noises, vibrations or binding in the controls. Keep an eye on all engine gauges. Anything unusual should be investigated.*

Climb over the field to 5,000 ft and level off reducing power to maintain 100 kts. Trim in pitch to maintain level flight and note the indicator position. Record any tendency that the aircraft has to roll left or right and if the ball is in the middle. Record the cylinder head and oil temperatures for future reference.



Once you begin to feel comfortable with the aircraft and you are happy with the engine operation and temperatures, reduce speed to 75 kts and carry out a few gentle turns.

Now try a few gentle stalls, reduce power to idle making sure first that the area is clear of traffic.

The stall should be preceded by a slight airframe buffet but until you have fitted the stall strips later in the test programme this buffet may be non-existent. Keep the ball centred as you approach the stall and prevent any further wing drop by use of rudder preventing further yaws. Make a note of the airspeed and verify this with another stall.

Climb back to 5,000 ft and now carefully lower the flaps at 70 kts. Familiarise yourself with the handling of the aircraft in this configuration.

Note any roll or yaw tendencies in this configuration.

Keep an eye on the engine gauges.

Once again reduce the power to idle and carry out a few gentle stalls making a note of the speed. There is more likely to be a wing drop with the flaps down so be prepared to recover with top rudder.

Use a speed 15 kts above the stall speeds for the clean approach and the flaps down final approach. 60 Kts is a good general guide for the final approach speed

The first flight should not exceed 15 — 20 minutes.

After the stall tests return to the airfield and prepare for an approach to land.



Europa Aircraft Co

Knowing the stall speeds and familiarising yourself with the slow speed handling characteristics should give you the confidence to make a good approach and landing.

Landing

Fly your calculated approach speed down to about 20 ft of the runway. Smoothly close the throttle allowing the Europa to continue down the glide slope. Flare in the normal manner to a small nose up attitude allowing the aircraft to slow down and sink onto the runway on its main gear first..

Note: *Being a little fast on your first approach is no bad thing but be prepared for a significant amount of float.*

Once on the ground, keep straight with rudder and brake gently as required.

If a large bounce occurs open the throttle slightly to cushion the next landing or simply go around using full throttle. Don't push the stick forwards, otherwise the next touchdown will be harder than the first.

Remain within gliding distance of the field until at least 5 hours of satisfactory trouble free operation has been achieved.

After first flight give the entire aircraft a general inspection. Attach any trim tabs that are necessary to the rudder or ailerons. Complete a thorough inspection of the aircraft after each of the first six flights.

Further flight testing

Make a note of pitch trim setting for take-off, then placard this position on the trim indicator.



As the pilot becomes more familiar with the aeroplane and the systems the known performance envelope may be expanded. The pilot will also become more familiar with the take off and landing technique.

Note: *You are test-flying a brand new aircraft and you should treat it as a kind of prototype. Do not assume that your aircraft will have the same characteristics as the company's prototypes or someone else's Europa.*

Minor builder modifications and slight variations can cause large differences in performance, handling, stall characteristics, C of G range etc.

Airspeed indicator calibration

Although your ASI may have been calibrated on a test rig before installation in the aircraft, errors due to the position of the pitot/static tube may come into effect and need to be checked. If your formation flying skills are up to standard you could formate on a certificated aircraft flying steadily at given speeds and note any differences on your ASI. Carry an observer to take down the numbers and so leave you free to concentrate on the flying.

If you have a G.P.S. (Global Positioning System) on board, fly into and out of wind at steady indicated airspeeds noting the ground speed read-out both ways then divide their total by 2 to obtain the actual airspeed. Don't forget to take into account the effect of density altitude.

Fitting stall strips

Once you have completed your first few flights and are feeling comfortable with the aircraft review the stalls both clean and in the landing configuration.



Europa Aircraft Co

Make careful notes of exactly what happens in terms of airframe buffet, the air speed at which the buffet is felt, whether it is mild or quite marked. Is it accompanied by wing rocking or the nose pitching up and down etc. and does one particular wing always drop?

At what I.A.S. does the stall occur and does the A.S.I. actually give good indications down to the stall?

Although there is wash-out built into the wing to encourage the stall to start from the inboard section stall strips are fitted to the inboard leading edge to act as a trigger to stall that part of the wing first. The stall strips consist of small triangular pieces of wood that are initially taped to the leading edge and, once the optimum position has been found, are bonded permanently into place.

When correctly fitted, the stall strips should give a more marked buffet with a greater margin between the onset of buffet and the stall. You ideally want a 5 kt margin.

A more gentle and benign stall is more desirable than a sharp G break and/or a possible wing drop. If, for instance you have one particular wing that always drops then by adjusting the stall strip on the other wing they can be made to stall together. The strips will need careful adjustment on the leading edge.

When we first fitted stall strips to G-YURO we found that even at full aft stick the stalling behaviour was very benign with no wing drop. We had, however, increased the stalling speed by approximately 7 kts.

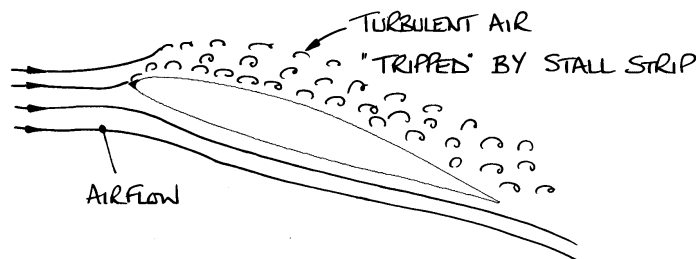
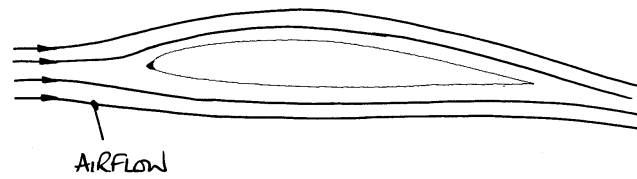

We could not understand initially why we were now doing rather heavy landings until we realised that we were stalling the aircraft in the flare.

We had placed the stall strips too far up the aerofoil and this was triggering the stall too soon.

How stall strips work

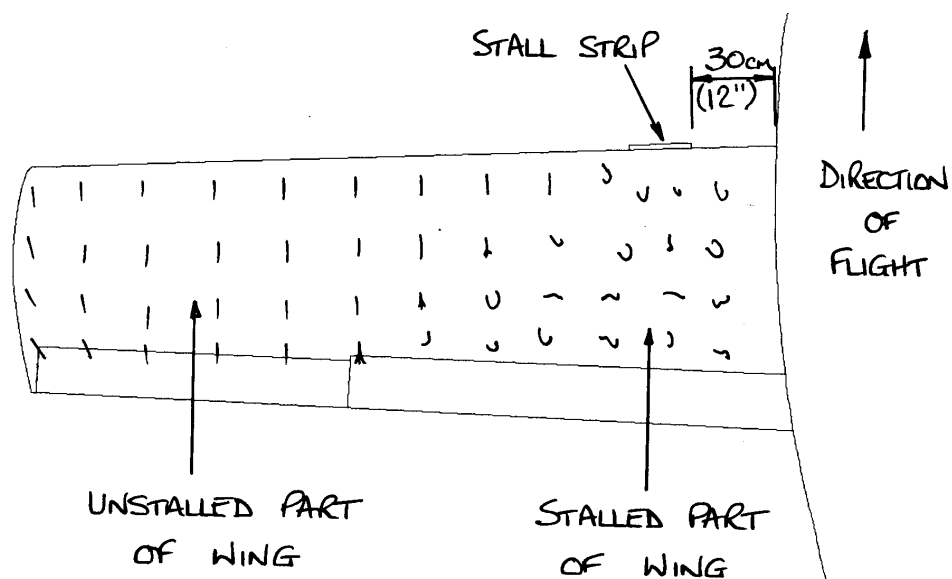



Europa Aircraft Co

In the cruise or when the wing is at a low angle of attack the stall strips do nothing.

As the angle of attack is increased the stall strips start to “trip up” the airflow over that part of the wing. This then acts as a trigger and spreads the stall across the rest of the wing.

Imagine lines of people running over a field. If one person was tripped up and fell he would, more than likely, trip up the people on either side of him spreading the chaos.

To help you see what is happening to the airflow over your wings you can fit “flow visualisation aids” or short tufts of wool 5 — 7cm (2" — 3") long. These are attached to the top surface of your wings by small pieces of masking tape at approximately every 20cm (8").

In the cruise all the tufts should be aligned leading edge to trailing edge and motionless indicating smooth attached airflow. Interestingly, you may notice that at the wing tip the tufts may be aligned with their ends slightly inboard indicating that air is flowing around the wing tip from the higher pressure air under the wing. This, of course, is quite normal.

As the angle of attack of the wing is increased approaching its stall angle, you will start to see the tufts become agitated and then flail about in all directions as that part of the wing stalls.

Firstly attach the tufts to your wings and look at the stalls again *without* the stall strips fitted.

You will be able to see visually and quite dramatically what is happening to the airflow at the stall.



Hopefully the stall will start at the inboard end of your wings and slowly spread outboard. This will give a gentle stall, the turbulent air from the inboard section of the wing should strike the tailplane and give airframe buffet. All very good.

What you may find is that no sooner has the inboard section started to stall than the whole wing unzips. You will see the stall spread across the wing very quickly. This will mean that you will have a more sudden stall and possible wing drop and less of a speed margin from the onset of buffet to the stall.

The aim is that by carefully fitting and positioning the stall strips we can achieve a progressive benign stall with good buffet warning and a 5 kt speed margin between the onset of buffet and the stall.

Once you have got a good feel for what is happening in the stall on your aircraft and have carefully noted exactly the results, fit the stall strips.

Make the stall strips of the section shown and tape them onto the wing 30cm (12") from the root using the template at the end of this section. Check the stall strip's positioning at both ends.

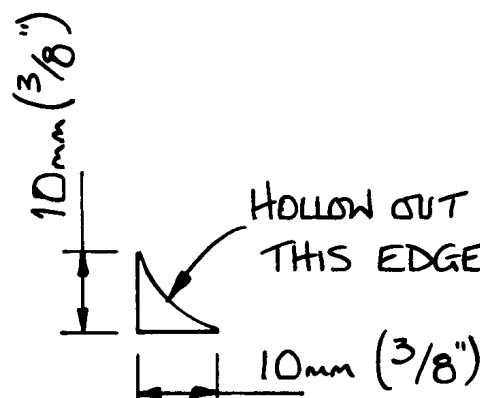

Stall strip section. Make two from wood 23cm (9") long



Europa Aircraft Co

Make the template (shown full size at the end of this section) with stiff card to fit over the leading edge of the wing and position the stall strips for the initial stall test.

The stall strips are very powerful, fitted wrongly they can seriously extend the take off run and lead to a stall whilst flaring the aircraft to land.

By moving the stall strips up the aerofoil or leading edge of the wing the onset of the stall will come sooner or at a lesser angle of attack. By moving them down the aerofoil they become less effective.

Start with the stall strips as positioned by the template then fly the aircraft and evaluate what effect, if any, they are having on the stall characteristics of your aircraft.

Move them up or down the aerofoil in small increments of 1 mm (1/20") and carry out another flight.

The aim is to achieve a gentle stall with a warning buffet preceding it.

But, do not over do it and limit the angle of attack of the wing so much that it increases the stalling speed by 5 kts or more and endangers the ability of the aircraft to flare in the landing configuration.

Note: *Re-check the stall characteristics at the aft C of G position when you extend the aircraft loading and flight envelope.*

IMPORTANT NOTE: *The fitting of stall strips and the stall assessment flying should be carried out by a pilot experienced in stall handling.*



Envelope expansion

Once you have confidence in handling you can start to expand the loading and flight envelope of your Europa. The important thing here is to do this in *small increments*.

Do not simply load it up to gross weight, aft C of G and take off in a 15 kt cross wind and dive to V_{ne} . This would be a totally stupid thing to do.

Extend the speed envelope in 5 kt increments checking for engine/propeller vibrations, temperatures and pressures etc. Trim to each new speed confirming that you have sufficient trim and control. With hands and feet off the controls note any out of trim condition.

Carefully “tap” the control column and rudder pedals to confirm freedom from vibration or flutter.

Important: *If any vibration of the flight controls is experienced discontinue the test immediately and report to Europa Aircraft.*

Similarly, extend your weight and C of G envelope in small increments noting the differences in the handling characteristics.

Do not assume that your aircraft will be exactly as the company prototypes. Be prepared to restrict your C of G envelope if necessary.

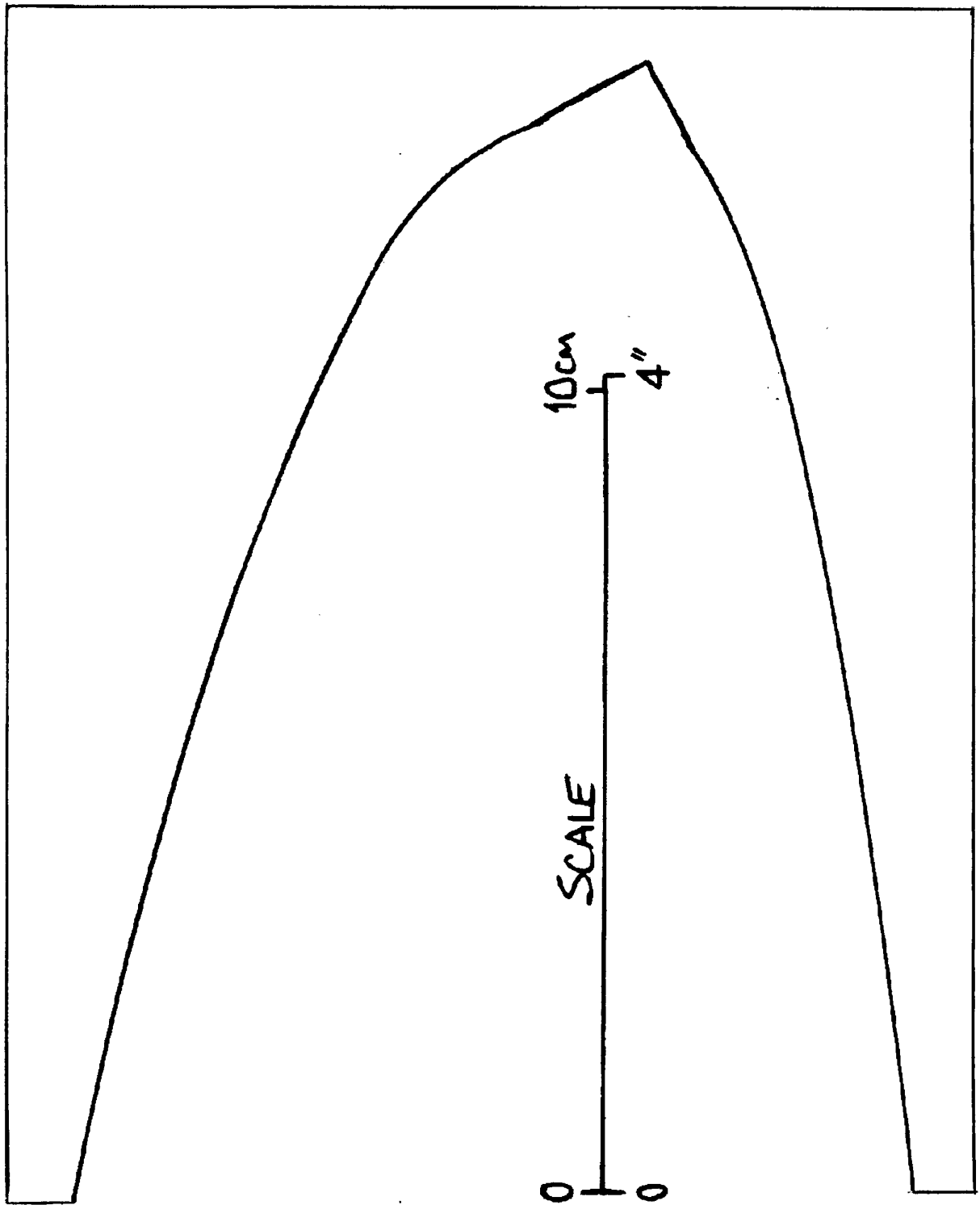



SECTION 10

Safety information

The Europa aircraft offers the pilot/owner a total utility performance package that is much greater than the normal certified aircraft.

Its ability to be kept at home on its own transporter, towed behind a car to a grass strip and then cover long distances at high speed all bring and demand more knowledge, skill and experience than simply renting a Cessna 150 from your local flying club.

You must be familiar with loading and securing the aircraft safely and towing a long trailer behind a car. Be familiar with all traffic regulations and speed limits in force for towing a trailer.

Practice rigging and de-rigging the aircraft, make a check list if necessary. It is wise to have a board with holes in which the main wing pins and pip pins are stored. That way they will not get lost or be mixed up with other *incorrect* pins that you may have in your workshop or tool box.

Do not become distracted whilst rigging the aircraft. If you arrive at an airfield and start rigging your Europa people seem to appear out of the woodwork to see what is going on. People asking questions. Did you build it? How fast is it? What is it? Is it a glider? can easily distract you. Always carry out a final close rigging inspection and then do it again on your pre-flight inspection. Do not assume that you are infallible.

Remember: *more freedom = more responsibility*

The ability to operate from short strips will demand more skill from the pilot. Just because someone else flies their Europa into or out of a particular strip does not mean that *you* can.



Europa Aircraft Co

The skill level required between flying from a large airport and a private grass strip could be tenfold.

Do not be caught out trying to operate from a strip that is within the aircraft's capability but beyond yours.

If you intend operating from short grass private strips then first practice from long wide ones. A pilot should have made a minimum of 100 successful landings in the Europa before considering operating from short, narrow or undulating rough strips.

Fly within your skill and level of experience.

The Europa is a real pilot's aircraft. Its crisp, responsive controls and excellent field of view make it a delight to throw around the sky.

BUT!!

Don't let it bring out the hooligan in you. Always fly responsibly.

One of the major causes of fatal accidents in home built aircraft is the "hooligan fly past". Our builder intent on impressing everyone with his "new bird" beats down the runway the wrong side of VNE, pulls up into an impressive zoom climb and then just as he runs out of airspeed and brains, decides to do a cross between a wing over, stall turn and half Cuban. The result is sadly all too often a fatal stall/spin tragedy.

The above is often carried out by pilots whose last steep turn was demonstrated to the examiner for the issue of their P.P.L. twenty years ago.

Unless you have the experience of throwing aircraft around the sky get it at a safe height with an instructor sat next to you.



Do's

- * Be thoroughly familiar with your aircraft, know its limitations and your own.
- * Be current in your aircraft, or fly with a qualified instructor until you are current/proficient.
- * Plan all aspects of your flight including weather and fuel reserves.
- * Use services available : In-flight weather information, radar advisory, flight following etc.
- * Carefully rig and pre-flight check your aircraft.
- * Use the check list in this manual.
- * Be sure that your weight and C of G loading are within limits.
- * Pilot and passenger must always wear the seat belts.
- * Be sure all loose articles and baggage are secured especially for takeoff and landing.
- * Check freedom of all controls during pre-flight inspection and before take off.
- * Practice emergency procedures at safe altitudes and airspeeds, preferably with a qualified instructor until all the actions become automatic.
- * Keep your aircraft in good mechanical conditions.



Europa Aircraft Co

- * Stay informed and alert.
- * Fly responsibly.

Don'ts

- * Don't attempt to take off with frost or ice on the airframe.
- * Don't fly in a reckless, show off or careless manner.
- * Don't fly near thunderstorms or severe weather.
- * Don't fly close to mountainous terrain.
- * Don't apply control force abruptly which could exceed the design loads of the aircraft.
- * Don't fly when physically or mentally exhausted.
- * Don't trust to luck.

Warning: *The Europa, because of its composite structure, is transparent to an electrical charge and does not comply with certified requirements for lightning protection. For this reason the Europa is prohibited from flight in conditions that would expose the aircraft to the possibility of a lightning strike.*



SECTION 11

Pilot experience requirements

Initial check out

There is no such thing as a minimum number of hours a pilot should have in his log book before being checked out to fly the Europa solo.

The best qualification, of course, is variety. A pilot who has only flown one type of aircraft will tend to expect the Europa to handle just like that one, whereas a pilot who has experience and is current in more than one aircraft will more quickly adapt to the differences in another aircraft type.

It is recommended that before soloing a Europa a pilot should be experienced on similar nose wheel aircraft with differential braking, and have flown at least five hours in the last month with two of these within the last week.

Before operating a Europa the pilot must be familiar with the entire contents of this manual.



Europa Aircraft Co

INTENTIONALLY BLANK



SECTION 12	Performance
-------------------	--------------------

Many factors will affect the performance of your Europa. Propeller pitch setting, build standard, weight, pilot technique, temperature, density altitude, etc., etc.

The figures given below are typical of Europa aircraft fitted with the Rotax 912 and 914 engines.

Rotax 912 performance figures

Europa fitted with a 3 blade 62" diameter Warp Drive propeller set to an incidence of 17° at the tip.

- * Top speed (sea level) 130 kts RAS
- * Cruise speed (75% at 8,000ft) 118 kts RAS
- * Rate of climb (sea level - 1300 lb) 700 fpm
- * Take-off ground roll 590 ft
(based on hard, dry runway).
- * Landing ground roll 656 ft
- * Range 650 Nm
(90 Kts economy cruise with 30 minutes reserve)



Rotax 914 performance figures

Europa fitted with a 3 blade 62” diameter Warp Drive propeller set to an incidence of 21° at the tip

- * Top speed (sea level) 140 kts RAS
- * Cruise speed (100% @ 10,000ft) 165 kts T.A.S.
- * Rate of climb (sea level - 1300 lb) 1300 fpm
- * Take-off ground roll 490 ft
(based on hard, dry runway).
- * Landing ground roll 656 ft
- * Range 650 Nm
(90 Kts economy cruise with 30 minutes reserve)

All aircraft

Stall speeds at gross weight

- * Clean 49 kts
- * Gear and flaps down 44 kts
- * Recommended glide speed clean 75 kts
(engine out)
- * Best rate of climb speed (V_y) 75 kts
- * Best angle of climb speed (V_x) 61 kts



- * Approach speed (flaps down at gross weight) 60 kts
- * Never exceed speed (V_{ne}) 165 kts
- * Manoeuvring speed (V_a) 97 kts
- * Maximum flap extension speed (V_{fe}) 83 kts

Important: *Note the performance of your aircraft and fly it accordingly.*

Note: *If you normally operate at gross weight and want to fly from a short grass strip all year round then it would be prudent to alter the propeller pitch to a finer setting to give a good take off performance and sacrifice maybe 5kts in the cruise.*

Experiment by adjusting the propeller pitch no more than 1° at a time. Remember that you do not want to exceed 5,500 r.p.m. in the full power climb. Increasing the static r.p.m. by just 200 r.p.m. makes quite a difference to the field performance.

